

SEMI-AUTOMATIC CARTON SEALING MACHINES



USA Series USA 2024-SB Side-Belt Drive

Side belt drive is an upgraded drive style. It captures the case between two moving belts reducing downward force on the case during processing. The USA 2024-SB is an ideal choice for processing narrow, lightweight, or void filled cases. Its selectable, floating upper assembly is perfect to process compressible overfills. With features like tilt-up top tape head, interchangeable 2" or 3" taping heads, standard top squeezers, adjustable infeed guides to retain the case during packing, reversible operator controls and telescopic leg extensions, the USA 2024-SB surpasses the competition and provides an affordable upgrade to world class performance.

*Shown with optional pack tables & casters

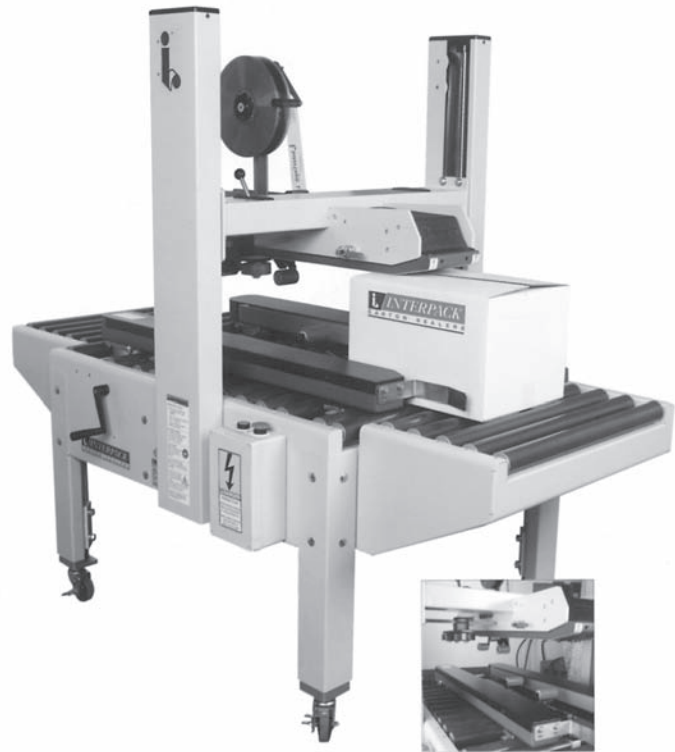

RSA Series Random Semi-Automatic*

Interpack's® RSA Series case sealers are operator fed machines that automatically adjust for the width and height of each case processed. When your production delivers different sized cases to be processed through a single case sealer, an Interpack Random Semi-Automatic Case Sealer is your answer.

Interpack offers a RSA series machine for every application. Whether you need to process small, large, light or heavy cases, we can provide the most effective solution. Complete your selection with an extensive list of unique standard options such as random top squeezers, foot pedal bypass or even automatic operations.

Features

- Dual column construction for maximum processing reliability
- Offset taping heads can process cases as low as 2" tall
- HSD® 2000-ET II Second Generation advanced taping head
- 1/3 HP gearmotors drive the bottom belts or side belts
- Self-tensioning & self-tracking belt drive
- Full-featured performance provides flexibility

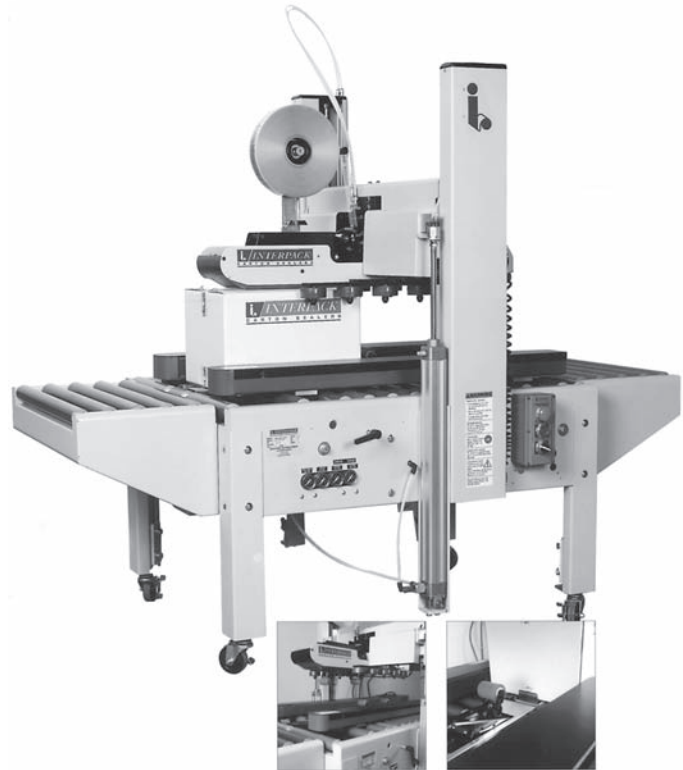

Available in Stainless Steel for Food Application

Ask us about our
“No-charge tape head program” and our **“Tape incentive machine discount”**