



rousseau NC TOOL STORAGE SYSTEM

We have designed a storage system to suit your needs.

Thanks to the various applications proposed, tools are protected during handling, storage and transportation of the tool rack.

VERSATILITY

The tool rack, at the core of our storage system, is compatible with the entire Rousseau product line. The compact and sturdy tool rack is equipped with practical, ergonomic handles making it easy to carry.

PATENT PENDING

FLEXIBILITY

The tool rack comes with perforations to insert Taper, Straight, Sandvik Capto, HSK, KM and VDI tools. The extruded PVC component is also offered without perforations.

SAFETY

With its original two-level design, the rack offers improved support and increased stability by preventing tools from falling out, even when the rack in an inclined position.

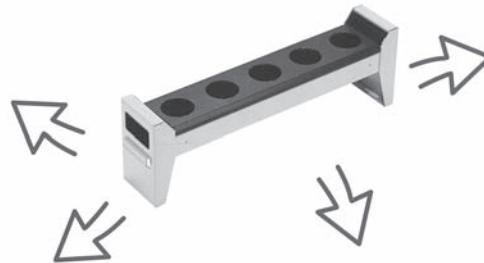

ACCESSIBILITY AND ERGONOMICS

Access to tools is made easy by integrating the tool rack with modular drawers, providing a 100% opening. Handling is also made easier in the Spider shelving and on the multi-purpose stand by the 20° inclination of the adaptors.



rousseau MODULAR WORKBENCHES

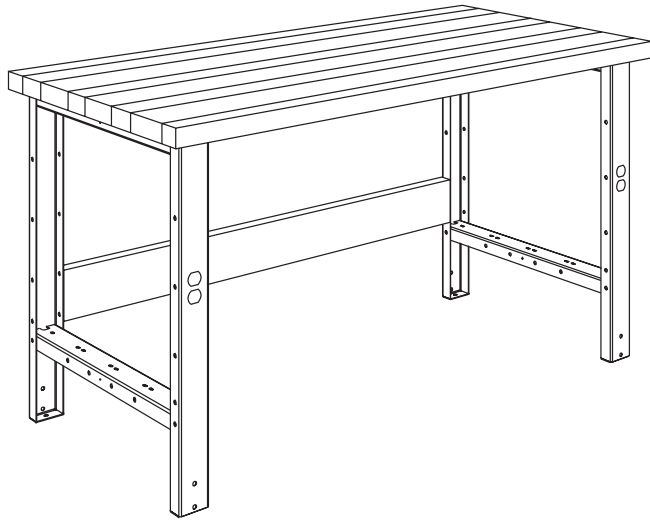

Open Type

Open Work Benches are of rugged steel construction for heavy duty use. All models feature heavy gauge channel formed steel legs with wide foot plate for stability, and for easy lagging to floor. Stringers provide greater bench rigidity and become a convenient back stop on models with shelves. Versatile modular design allows easy addition of accessories at any time.



Pedestal

Pedestal Work Benches feature rugged steel construction and allow easy addition of a full range of accessories. These benches are ideal wherever storage of tools or workpieces is required. Work Bench assemblies are available with many styles of pedestals. All are made from heavy gauge steel.

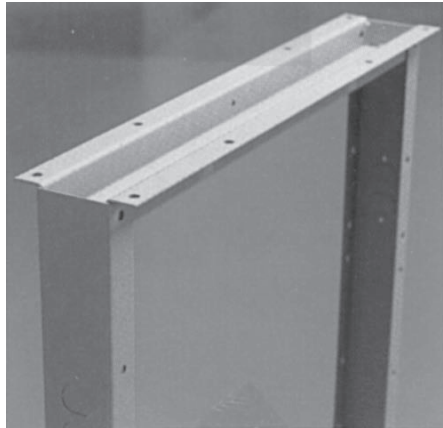

The inverted-hat design of the upper part of the leg provides excellent structural rigidity.



Ball-bearing sliders, with a 100lb capacity, allow drawers to open 100%, giving unrestricted access to their contents. Each drawer is equipped with dividing strips for flexibility.

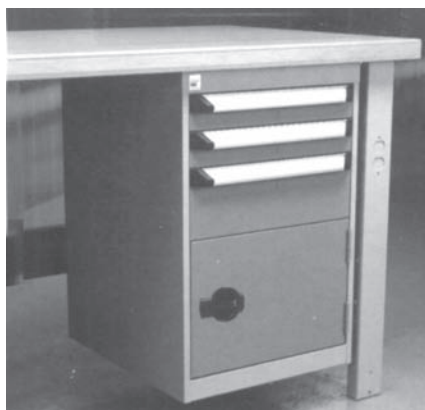
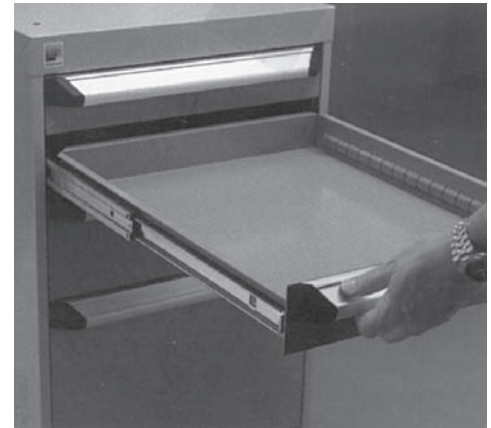

Suspended Pedestal



Modular Drawer Cabinet

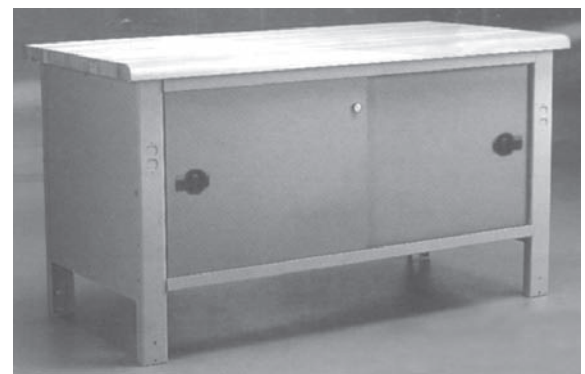

Closed Workbenches



rousseau MODULAR WORKBENCHES

Bench Tops

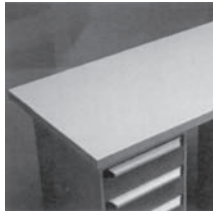

Painted Steel Top
12 gauge steel
1³/₄" thick
Double flange construction, front and back
2 wood cross bars for attaching cabinets and other accessories.

Can be reinforced and sound-proofed by adding a wood filler

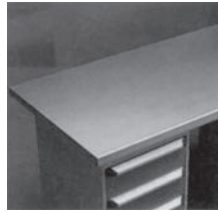

Stainless Steel Top
12 gauge steel
1³/₄" thick
Double flange construction front and back
2 wood cross bars for attaching cabinets and other accessories.

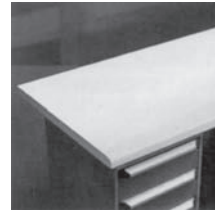

Dissipative Top
Colour: White
1⁵/₈" thick
Dissipates electric charges that can damage electronic components.
Resistance point to point and point to ground between 10⁶ and 10⁹ Ω

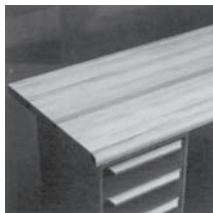

Laminated Wood Top
Made with varnished hardwood slats
1³/₄" thick
Robust and attractive

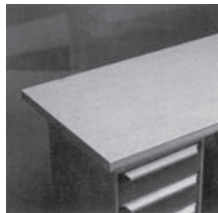

Wood Composite Top
Made from varnished wood composite boards and hardwood
1³/₄" thick
Extremely resistant to shocks, alkaline acidic substances, oils and greases.

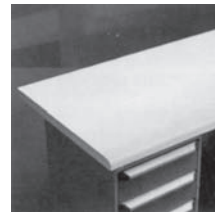

Plastic Laminate Top
Colour: White
1⁵/₈" thick
Clean, smooth surface

Pedestals

Drawers to store and find anything.
The 3" and 6" drawers, with 2 full-width dividers, are ideal for storing all kinds of small objects, such as hardware, tools, etc. 12" drawers are suited specially for larger objects or hanging folders. All drawers are equipped with ball-bearing slides and can be locked for added safety. Rousseau's aluminum handle enhances their aesthetic look. Drawers have 100 lb capacity and are 100% extensible. 4" base as shown. Sold separate (WS31-182104).



WS30-2351L3

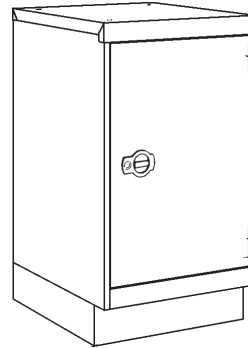

WS30-2352L3

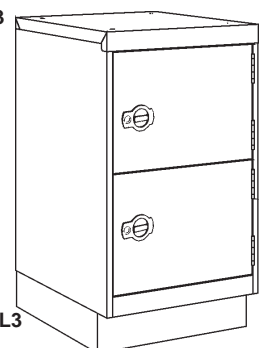

WS30-2353L3

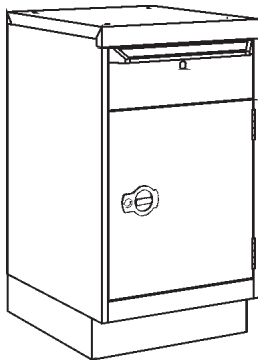

WS30-2354L3

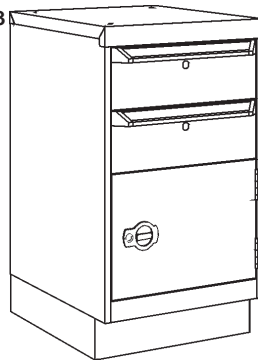

WS30-2355L3

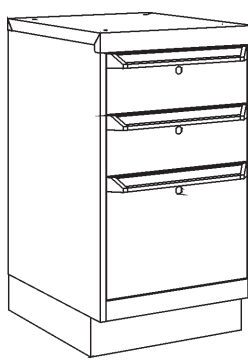

WS30-2356L3

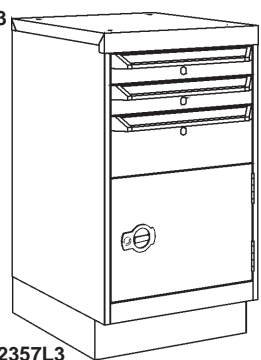

WS30-2357L3

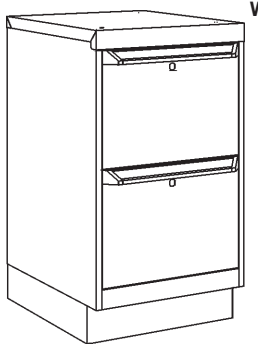

WS30-2358L3

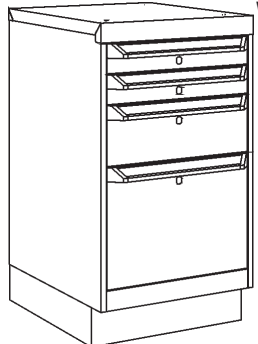

WS30-2359L3

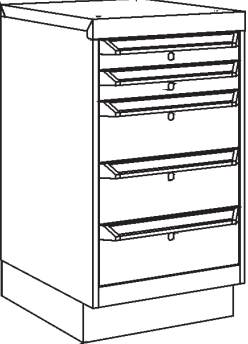

WS30-2360L3



Drawers WS34-3201L3

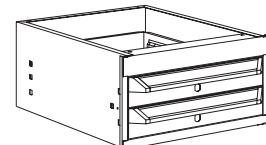

WS34-3202L3

Standard pedestals are 18" wide x 21" deep x 32" high. Pedestals are also available in heights of 28", 34" and 38". All pedestals are available 27" in depth.



rousseau MODULAR WORKBENCH ACCESSORIES

Modular and flexible, all workstation accessories can be adapted to suit your present and future needs. Any arrangement is possible, above as well as below the work surface, thanks to a wide range of versatile and rugged products.

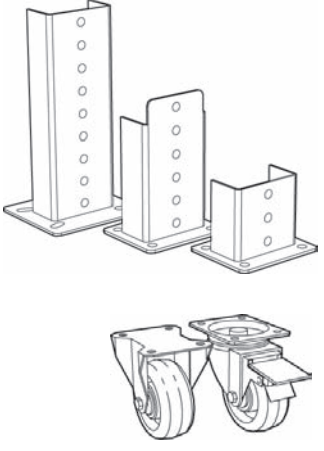
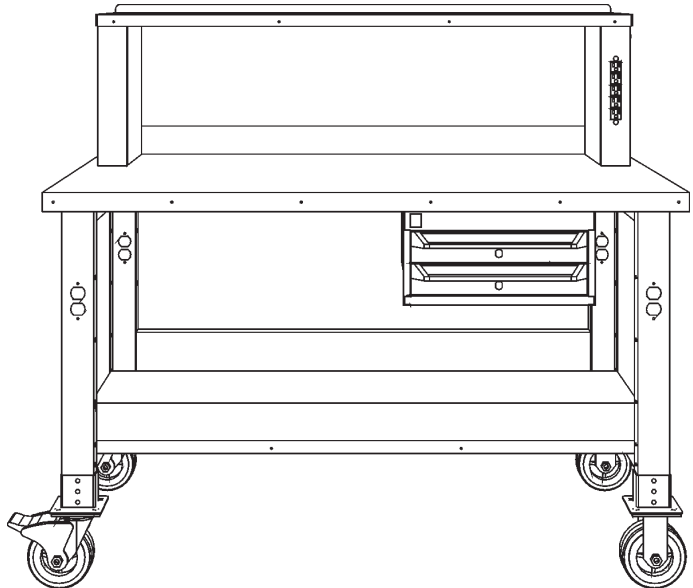
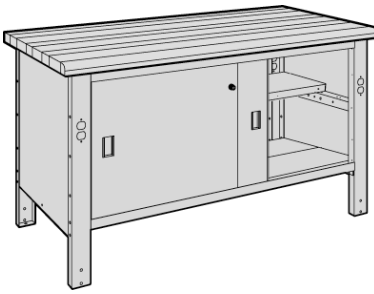
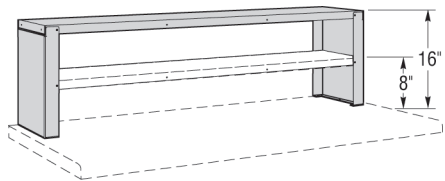
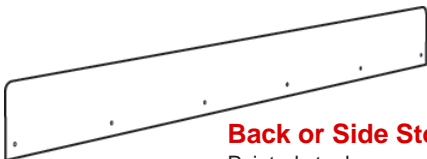
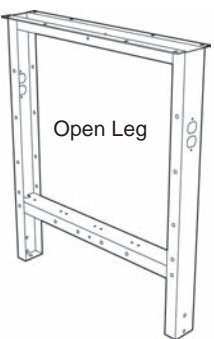
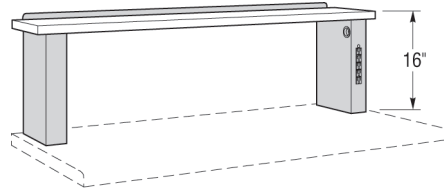
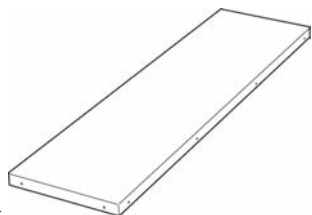
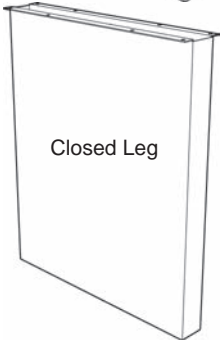
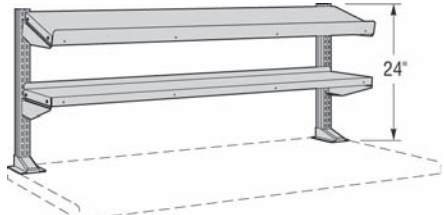
<p>Mobile Benches All 2-leg workbenches can be made mobile by adding casters and caster adaptors to legs</p>  <p>Leg Extensions Caster Adaptors Sold in pairs Three heights: 3", 6" and 9" The 6" and 9" adjust leg height</p> <p>3" Casters Sold in pairs Two caster options: Rigid Swivel with total brake (On wheel and swivel) 300lb capacity per caster Total height: 4"</p>		
 <p>Closed Table Model including: Your choice of top 2 legs 27"D x 32"H Sliding doors with lock Side and back panels 3 shelves 12"D 2 leg cross bars</p>	<p>Legs Exceptionally versatile and rugged structure Our regged steel legs are extremely rigid, even under the most demanding conditions. They are smooth-finished in front, since most accessories attach to their sides.</p>	<p>Top Shelf Units</p>  <p>Econo Riser Shelf 1 pair of econo reser shelf supports 1 or 2 steel shelves 12"D</p>
 <p>Back or Side Stop Painted steel Can be affixed on back or sides according to top dimensions May be installed on all types of tops 5" height. Clears top by about 3/4"</p>	 <p>Open Leg</p>	 <p>Riser Shelf with Electrical Outlets 1 pair of reser shelf supports with electrical outlets on one side 1 shelf of your choice, 12"D 1 shelf back</p>
 <p>Steel Shelf 18 gauge steel, 1 1/4" thick Can be installed on leg cross bars or on shelf supports Widths: 48", 60" and 72" Depths: 6" and 12" Shelf combinations: 21" deep legs: 1 shelf 6" + 1 shelf 12" 27" deep legs: 2 shelves 12", or 1 shelf 6" & 1 shelf 12"</p>	 <p>Closed Leg</p>	 <p>WM uprights with Adjustable Shelves 2 multi-purpose uprights 2 pairs of structural shelf supports 2 steel shelves 12"D 2 shelf backs</p>



rousseau MODULAR WORKBENCHES

Open Work Benches

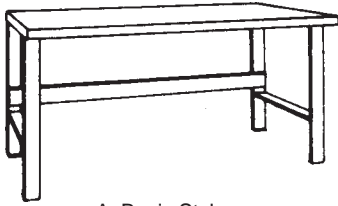

A. Basic Style

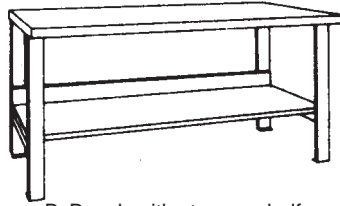

B. Bench with storage shelf

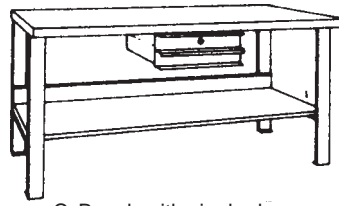

C. Bench with single drawer

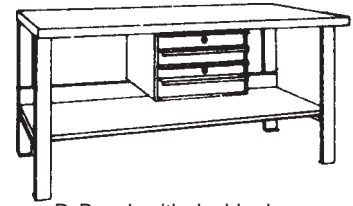

D. Bench with double drawer

Pedestal Work Benches

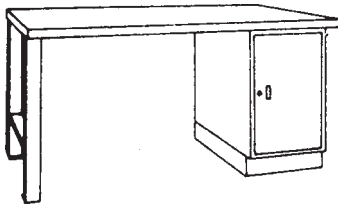

E. Single leg & Single door pedestal

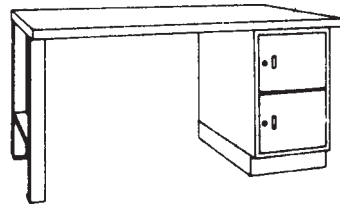

F. Single leg & Double door pedestal

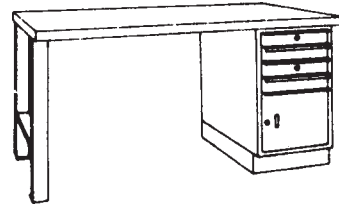

G. Single leg & Double drawer single door pedestal

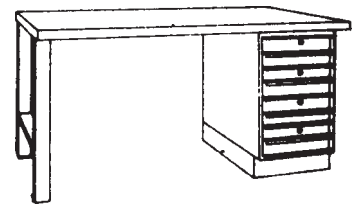

H. Single leg & Four drawer pedestal

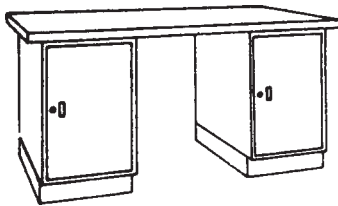

I. Two single door pedestals

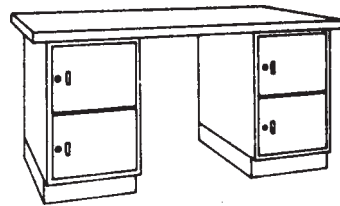

J. Two double door pedestals

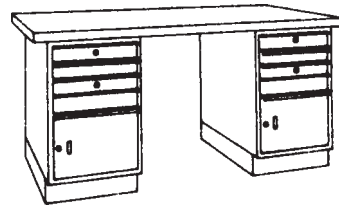

K. Two double drawer, Single door pedestal

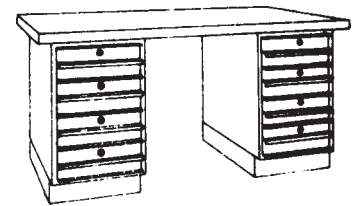

L. Two four drawer pedestals

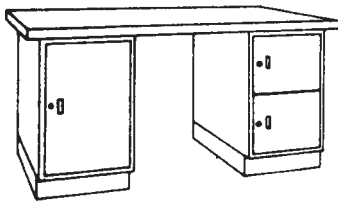

M. Single door & Double door pedestals

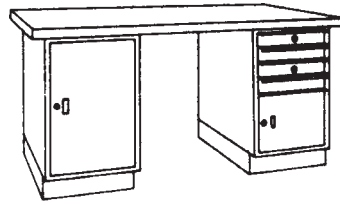

N. Single door & Double drawer, Single door pedestals

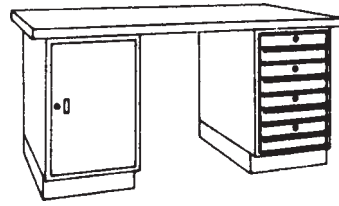

O. Single door & Four drawer pedestals

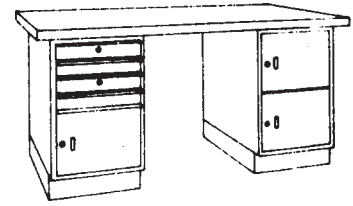

P. Double drawer, single door & Double door pedestals

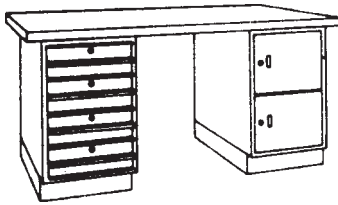

Q. Four drawer & Double door pedestals

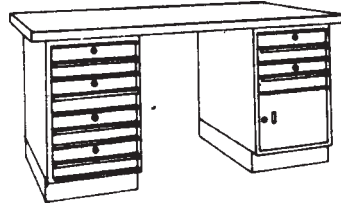

R. Four drawer & Double drawer, Single door pedestals

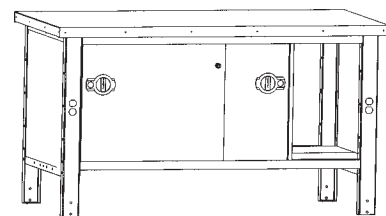

S. Sliding door bench

When ordering, please specify:

Select from A to S

Type of top:

S = Steel

SW = Steel, wood filled

LW = Laminated wood top

Available sizes:

Size No.	Depth x Width
2448	24" x 48"
2460	24" x 60"
2472	24" x 72"
3060	30" x 60"
3072	30" x 72"
3660	36" x 60"
3672	36" x 72"

Example:

Part No.	Bench Type	Top Style	Top Size
A	A	S	2448
Descr.	Basic Style	Steel top	24" x 48"



rousseau MULTI-PURPOSE FRAME

Suited to a wide range of application: • Basic Station • Quality Control Station • Repair/tool Station • Assembly Station
• Laboratory Station • Packaging Station • Customized Work Station

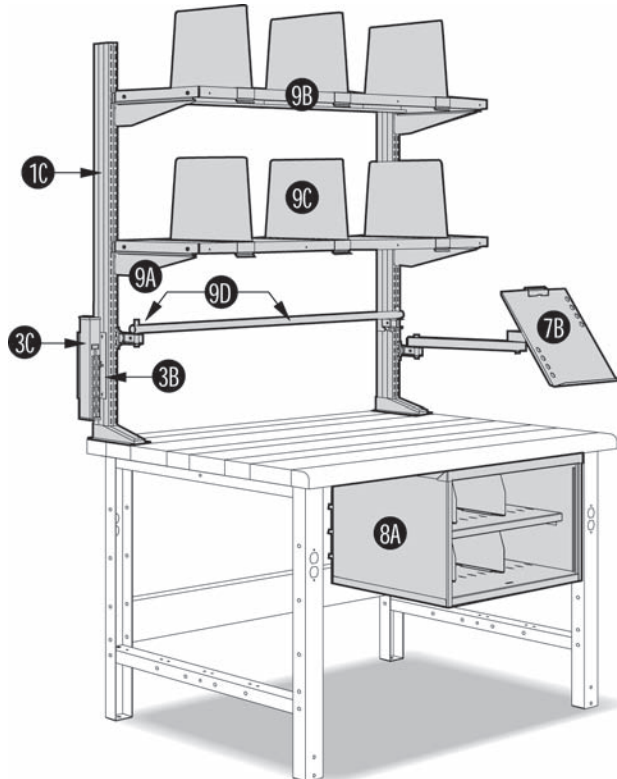
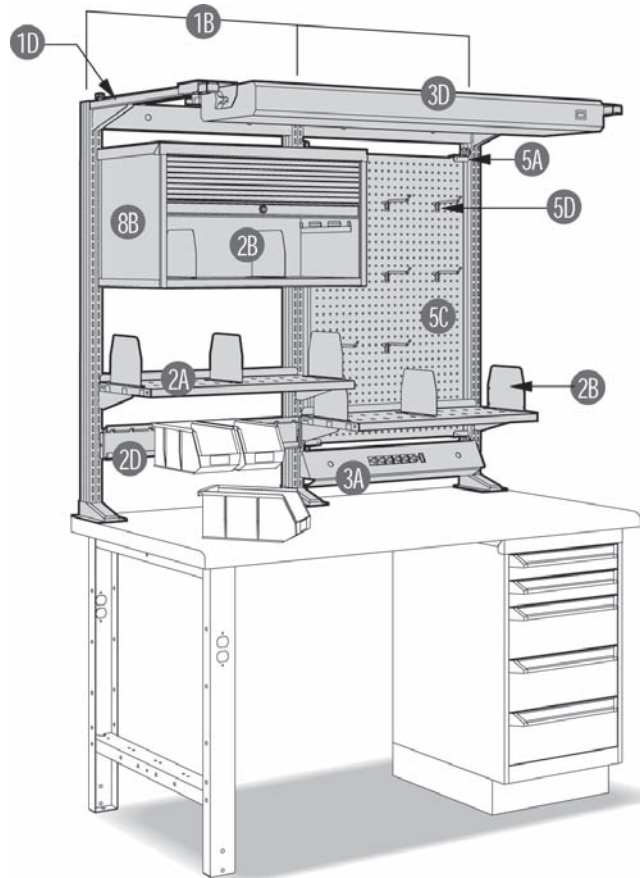
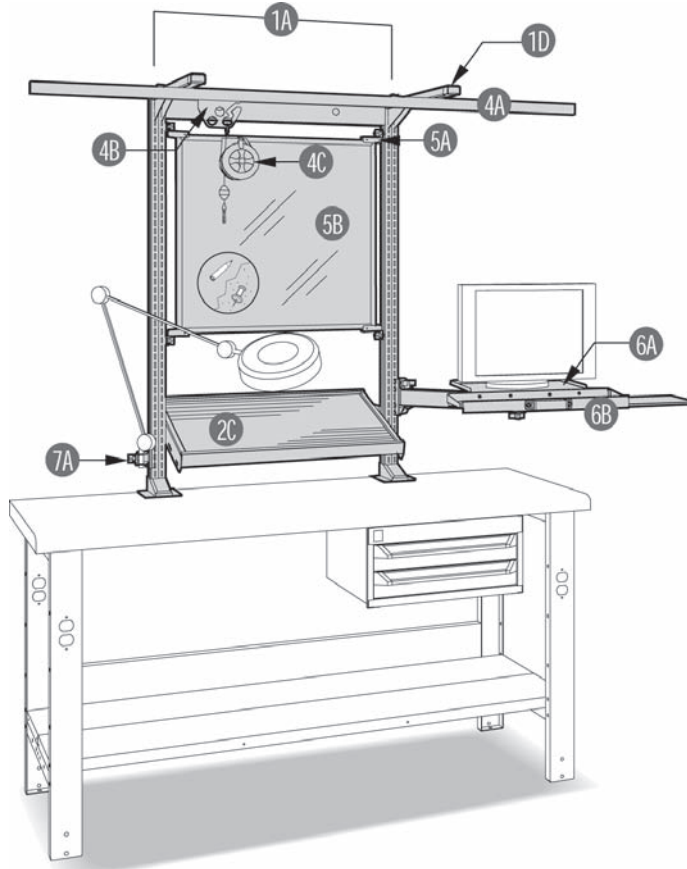

Main Components

1. Structural Components

- 1A Single WM unit frame (2 uprights)
- 1B Double WM unit frame (3 uprights)
- 1C Multi-purpose upright
- 1D Cantilever overhead supports (pair)

2. Basic Components

- 2A Tilttable shelf
- 2B partial divider
- 2C Tilttable pan
- 2D Plastic bin rail

3. Power and Lighting

- 3A Power outlet channel
- 3B Vertical adapter for electrical and air outlet
- 3C Power outlet strip
- 3D Overhead work station light

4. Components for Overhead Tools

- 4A Tool rail
- 4B Balancer trolley
- 4C Tool Balancer

5. Panels

- 5A Panel bracket kit
- 5B Tackboard and marker panel
- 5C Perforated panel
- 5D Hook for perforated panel

6. Trays on Articulating Arm

- 6A Monitor tray with arm
- 6B Keyboard and mouse tray

7. Components on Light-Duty Arm

- 7A Magnifying or task lamp adapter
- 7B Document holder with arm

8. Storage Cabinets

- 8A Storage cabinet
- 8B Storage cabinet with a roll-up door

9. Packaging Station Components

- 9A Structural shelf supports
- 9B Steel shelf
- 9C Sliding divider
- 9D Paper and cardboard spool support



rousseau MOBILE BENCHES

These units combine the work surface of a bench, the storage facility of a cabinet table and the mobility of a service cart. Designed for moving heavy parts and tools to the job site and providing a strong, maintenance-free surface to work on.

Used by maintenance mechanics, electricians, carpenters and other service men.

Mobile benches come with locks for added security. Standard colour: Light grey with classic blue doors and drawers.

Other colours available. See S16 for interchangeable pedestals.

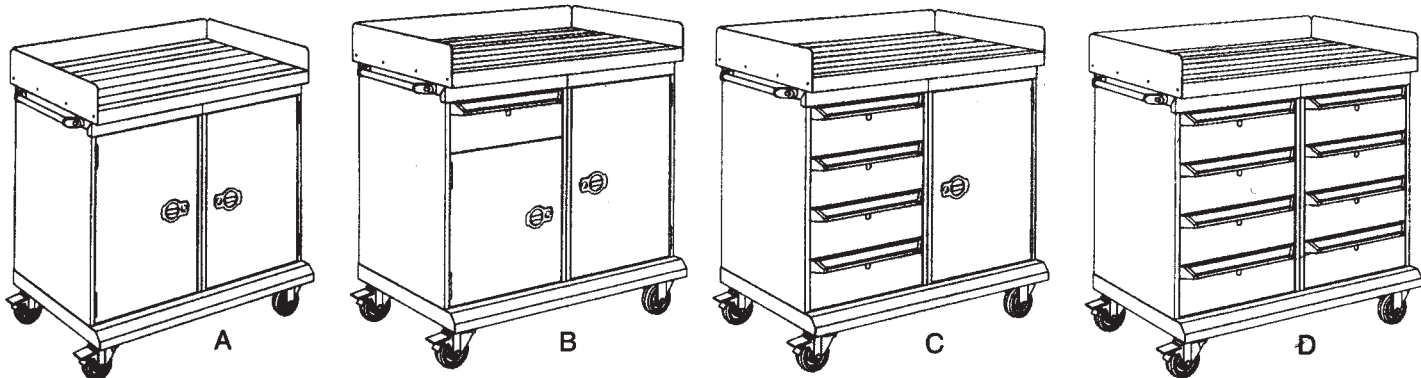

*Shown with optional 1 3/4" hardwood top. (1" grey melamine tops also available)

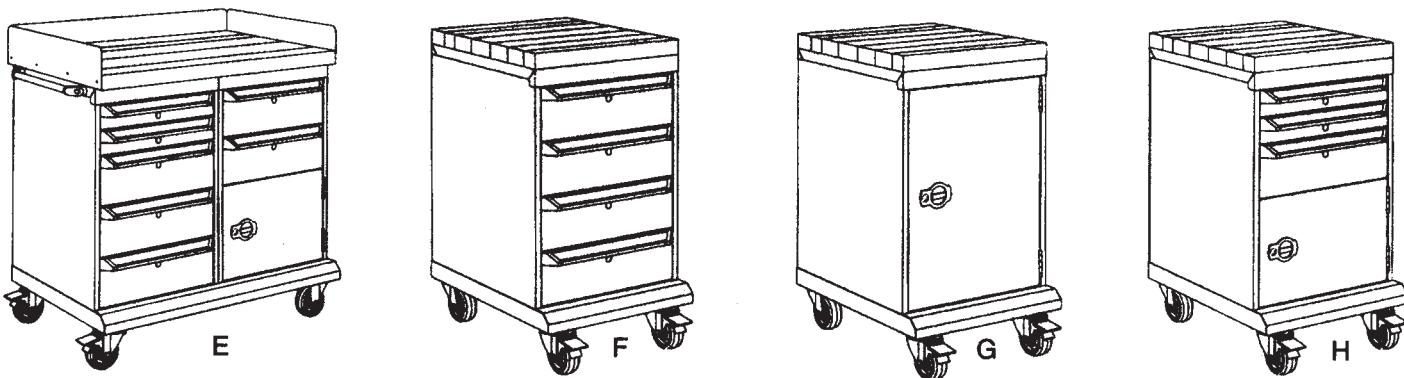

*Shown with optional top. (Sides and back stops also available).

Model No.	Unit Description	Dimensions (") W x L x H	Wt/lbs
A. MB5252	2 Door	24 x 36 x 36	136
B. MB5452	1 Drawer / 2 Doors	24 x 36 x 36	143
C. MB5152	4 Drawers / 1 Door	24 x 36 x 36	163
D. MB5151	8 Drawers	24 x 36 x 36	190
E. MB6055	7 Drawers / 1 Door	24 x 36 x 36	202
F. MB5100	4 Drawers	24 x 18 x 32	98
G. MB5200	1 Door	24 x 18 x 32	71
H. MB5700	3 Drawers / 1 Door	24 x 18 x 32	86

*Optional tops: Hardwood, Steel, Plastic Laminate and Stainless Steel

WORKBENCHES



Model No: W2436



2500 lb capacity

Heavy Duty Machine Stands

These machine stands are designed for use as a machinery stand, or as a work table when a full sized workbench is not necessary. Features include: All welded 14-gauge steel, 1 1/2" lip-down shelves, bolt down footplates on each leg, and blue enamel finish.

Model No.	Dimensions D" x W" x H"	Cap. Lbs	Wt. Lbs
W1824	18 x 24 x 32	1800	50
W1830	18 x 30 x 32	1500	60
W1836	18 x 36 x 32	1500	65
W2436	24 x 36 x 32	1500	70
W2442	24 x 42 x 32	1000	75
W2448	24 x 48 x 32	1000	85

Pedestal Bench

Designed for workshop applications, these benches feature a 1 3/4" thick solid laminated hardwood top mounted on a pair of all-welded 2 shelf pedestals (18"W x 24"D x 32"H each). Overall height is 33 3/4". Pedestal colour is blue.

Model No.	D" x W" x H"	Wt/Lbs
805-3060	30 x 60 x 33 3/4	158
805-3072	30 x 72 x 33 3/4	175
805-3084	30 x 84 x 33 3/4	192
805-30120	30 x 120 x 33 3/4	245
Pedestal only		
805-1824	18 x 24 x 32	50

36" deep units available upon request.



Model No: MB300



Model No: MB301



Model No: MB305



Model No: MB310

Model No.	Unit Description	Wt/Lbs
MB300	2 door	235
MB301	1 drawer/1 door	190
MB305	4 drawer/1 door	275
MB310	8 drawer	300

MOBILE SERVICE BENCHES

These units combine the work surface of a bench, the storage facility of a cabinet table and the mobility of a service cart. Designed for moving heavy parts and tools to the job site and providing a strong, maintenance-free surface to work on. Used by maintenance mechanics, electricians, carpenters and other servicemen. Rugged, welded construction features a laminated hardwood top. Rolls easily on two rigid and two brake type swivel casters.

Features Include:

- **Steel Back & End Stops** keep parts and tools from falling off.
- **Drawers** can be individually locked by purchasing optional cylinder locks.
- **One piece all welded cabinet** construction saves assembly time, is more rigid and has a better appearance.
- **Laminated hardwood top** 24"D x 42"W x 37"H.
- **1000 lbs.** capacity.
- **Blue** finish.

SHOP DESKS AND CABINETS



A



B



C



D

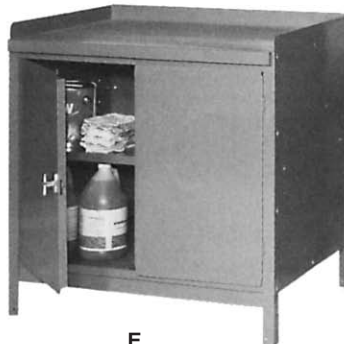

E

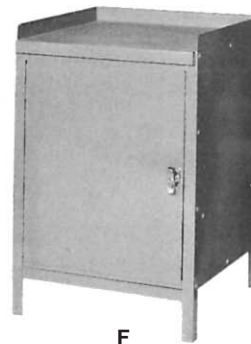

F



G

A. WALL MOUNTED SHOP DESK

A space saver. The large 34 1/2"W x 30"D desk top provides a convenient writing area without utilizing valuable floor space.

Comes with one large storage compartment and a 31" W x 20"D x 3 1/2"H locking drawer on full extension ball bearing drawer slides. Wall mount brackets included. Durable powder coat grey finish. Shipped knocked down.

Model	Wt. Lbs
HD011	85

B. FLOOR MODEL FOREMAN'S DESK

Ideal for shipping and receiving clerks, watchmen and shop foremen.

Comes with one large storage compartment and a 31"W x 20"D x 3 1/2"H locking drawer on full extension ball bearing drawer slides. Sloping writing top is 43" high at front. Overall dimensions: 34 1/2"W x 30"D x 53"H. Heavy gauge steel finished in durable powder coat grey. Includes a lower storage shelf. Shipped knocked down.

Model	Wt. Lbs
HD080	105

C. CABINET STYLE SHOP DESK

This solid unit offers the convenience of the floor model foreman's desk, with a locking cabinet for added storage space. Sloping top is a comfortable 43" high at front. Comes with one large storage compartment and a 31"W x 20"D x 3 1/2"H locking drawer and double door cabinet. Overall dimensions: 34 1/2"W x 30"D x 53"H. Durable powder coat grey finish.

Model	Wt. Lbs
HD010	150

D. DELUXE SHOP DESK

4 drawers of filing/storage space and an 8 compartment sorter makes this an all-purpose desk for warehouses, shops and shipping and receiving departments. Comes with one tray drawer with cylinder lock, two double-deep file drawers with recessed handles, and one all purpose drawer. Desk top sorter keeps papers handy and organized. Use lower shelf for extra storage space or as a footrest. Overall dimensions: 39"W x 28 3/4"D x 55 1/2"H. Grey baked enamel finish.

Model	Wt. Lbs
660	163

CABINET TABLES

These sturdy combination storage cabinets and work tables provide safe locked-in storage of valuable tools and parts, while at the same time serving as all-around work tables. Ideal for mounting vises, grinders or small power tools. Heavy gauge steel. Cylinder lock built into handle on door for added security. Grey baked enamel finish.

E. LOCKING CABINET TABLE

36" x 24" table top offers a large work area; 2" deep lip prevents supplies from falling off. Comes with one full-size center shelf adjustable on 1 1/2" centers and 18 cu.ft. of storage space. Unit is 34"H. Shipped Knocked Down.

Model	Wt. Lbs
59243	110

F. ONE SHELF CABINET

24" x 24" work area with 2" lip. Comes with one full size center shelf adjustable on 1 3/4" centers; 12 cu.ft. of storage space. 34"H. Shipped Knocked Down.

Model	Wt. Lbs
59242	80

G. THREE SHELF CABINET

15 1/2" x 21" work surface can be mounted to form a 2" deep tray or reversed to provide a flat, rimless work area. Three adjustable shelves inside the 6.2 cu.ft. interior allow for concentrated storage. 32" working height; 34" overall height. Shipped Knocked Down.

Model	Wt. Lbs
630	46