



rousseau MODULAR DRAWER SYSTEMS

The rousseau Modular Drawer

With a new design and improved performance, the Rousseau Modular Drawer is the best in its category. It permits faster inventory and ensures greater efficiency. In fact, it is the base of a storage system which offers top performance with a minimum investment.



The full-length handle is designed to provide a good solid grip, even when you open a drawer carrying 400 pounds. Installed at the top of the drawer, it is easier to reach, especially with bottom drawers. The full length handle serves to clearly identify contents since it matches the inside width of the drawer exactly. An optional non-reflective plastic cover ensures better visibility and protects the label.

Choose the colour of the handle end caps to suit your working environment and enhance your drawers and cabinets. Whether your work space is dark or bright, you can choose from colour combinations appropriate for industrial, commercial or institutional work places.



A wide selection of drawer depths and partitioning configuration allows users to design their units to accommodate a variety of inventory.

This feature increases efficiency in inventory management and keeps items in a clean, organized environment. Optional on all units is a locking system.



rousseau MODULAR DRAWER SYSTEMS

Heavy-Duty Cabinet Housings

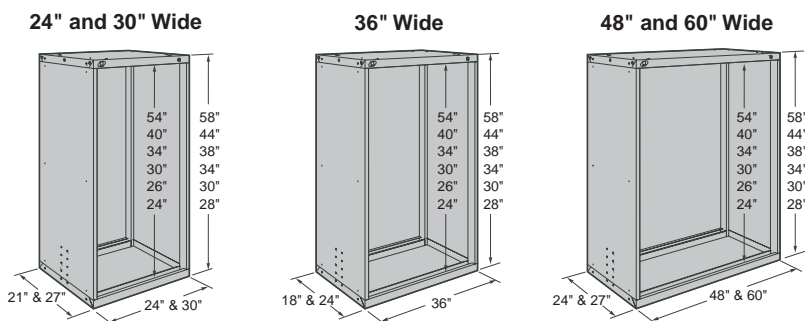

Available Heights

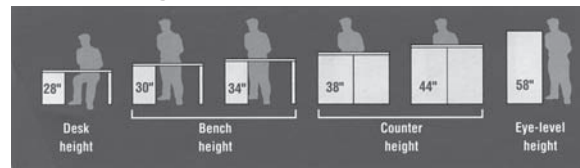

Drawer Dimensions

INSIDE DEPTH	INSIDE WIDTH					
	20"	26"	32"	38"	44"	56"
24"	24"x27"	30"x27"	36"x27"	42"x27"	48"x27"	60"x27"
18"	24"x24"	30"x24"	36"x24"	42"x24"	48"x24"	60"x24"
15"	24"x21"	30"x21"	36"x18"	42"x18"	48"x18"	

Drawer and Roll-Out Shelf Dimensions

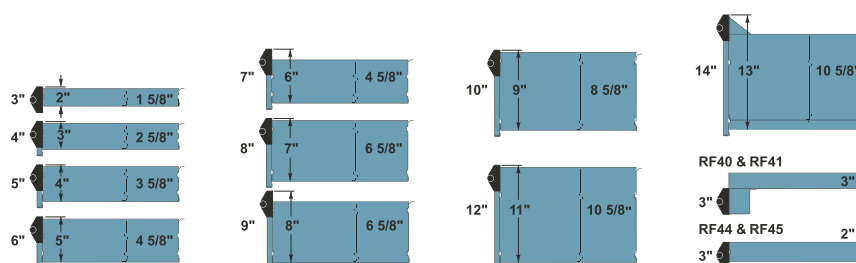

Compartment Dimensions

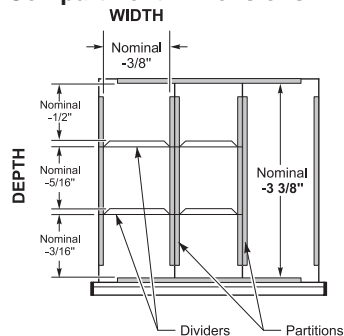

Cabinet Width x Depth

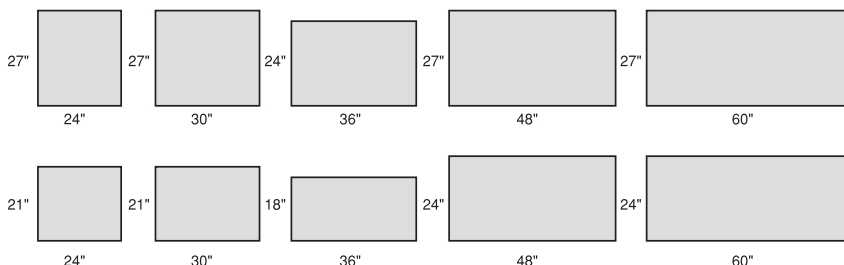

Front Access Forklift Base

RA52

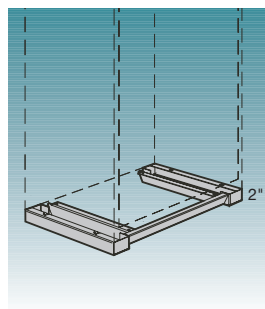

2" high base designed for moving the cabinet from the front with a forklift ;

Front cover plate included ;

Includes a recessed kick-plate in the center of the cabinet to allow user to stand closer to cabinet ;

Designed to enable user to anchor cabinet to the floor ;

Compatible with RA74 levelling glides ;

Compatible with the RA54 rear base cover plate, offered as an option.

Note : Not compatible with casters.

Note : Not designed for stacking applications.

Front and Side Access Forklift Base

RA53

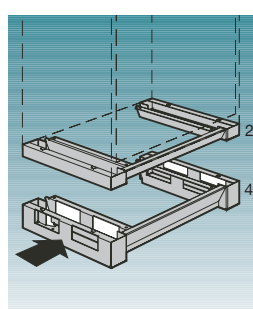

4" high base designed for moving the cabinet from the front or side with a forklift, or from the front with a pallet-jack ;

Front cover plate included ;

Includes a recessed kick-plate in the center of the cabinet to allow user to stand closer to cabinet ;

Designed to enable user to anchor cabinet to the floor ;

Compatible with RA74 levelling glides ;

Compatible with the RA54 rear base cover plate, offered as an option.

Note : Not compatible with casters.

Note : Not designed for stacking applications.



rousseau MODULAR DRAWER SYSTEMS

You can have your own custom-made cabinet, using the Rousseau options, which will meet all your needs.

A. Steel cabinet top with a rubber mat

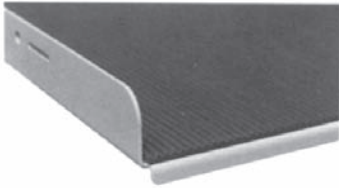

B. Laminated cabinet wood top



C. Doors



D. One-drawer-at-a-time locking mechanism

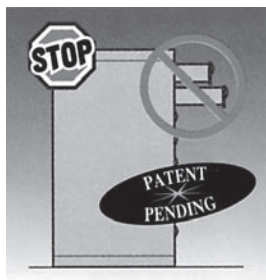

E. Individual drawer lock

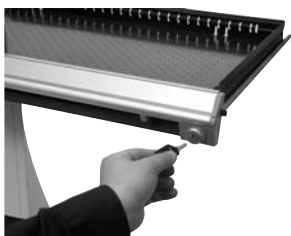

A&B Use your cabinet as a workbench or work surface. Tops protect cabinet surface. Steel tops with rubber mats, laminated wood tops and composition core tops are available.

C. Especially for cabinets with fixed or roll-out shelves. Doors protect against dust, theft and damage. Includes a locking mechanism. Please specify required type of keying* when ordering.

D. Prevents simultaneous opening of drawers to provide more stability to cabinet. Available on all models.

E. Provides added protection for limited access to all drawers.

F. Move entire contents in a single step. Includes a handle, rigid or swivel casters (with brakes).

G. Prevents accidental opening or closing of drawers in mobile units, vehicles or carousels. Factory installed on every drawer. Installation on site is also possible*

*With minor modifications to the drawer.

H. Allows ganglocking drawers in cabinets or shelving units. Ensures greater safety in vehicle applications. Can be used with a padlock (not included). Right-hand side application only. Fits most shelving units.

I. Ensures limited access to cabinet contents. Rousseau offers:
Key alike combinations (KA)*
Keys different (KD)*
Master keys (MK)*

F. Mobile cabinet



G. Lock-in / lock-out system



H. Vertical security bar



I. Cabinet lock





rousseau MODULAR DRAWER SYSTEMS

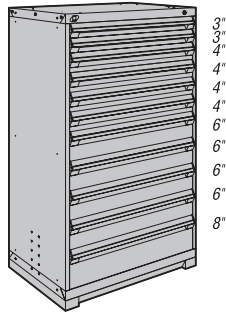

11 drawers
R5AEC-5803 36" x 18" x 60"
R5AEE-5803 36" x 24" x 60"

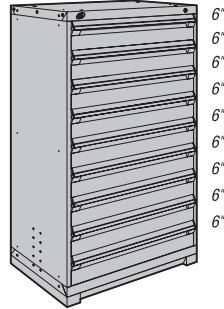

9 drawers
R5AEC-5813 36" x 18" x 60"
R5AEE-5813 36" x 24" x 60"

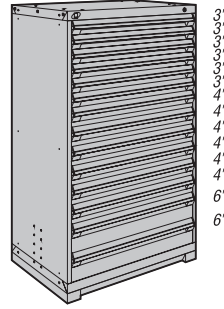

14 drawers
R5AEC-5817 36" x 18" x 60"
R5AEE-5817 36" x 24" x 60"

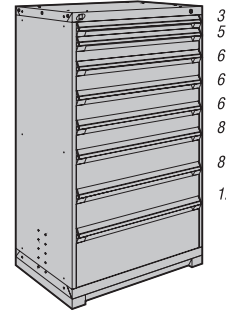

8 drawers
R5AEC-5825 36" x 18" x 60"
R5AEE-5825 36" x 24" x 60"

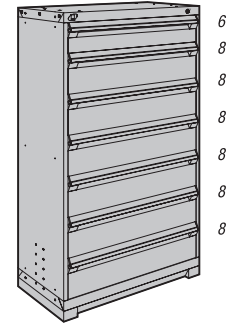

7 drawers
R5AEC-5833 36" x 18" x 60"
R5AEE-5833 36" x 24" x 60"

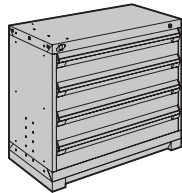

4 drawers
R5AEC-2801 36" x 18" x 30"
R5AEE-2801 36" x 24" x 30"

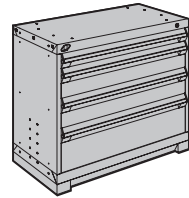

4 drawers
R5AEC-2803 36" x 18" x 30"
R5AEE-2803 36" x 24" x 30"

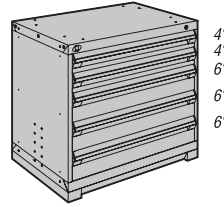

5 drawers
R5AEC-3005 36" x 18" x 32"
R5AEE-3005 36" x 24" x 32"

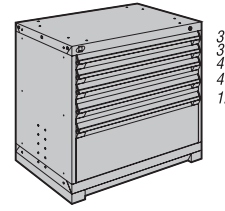

5 drawers
R5AEC-3011 36" x 18" x 32"
R5AEE-3011 36" x 24" x 32"

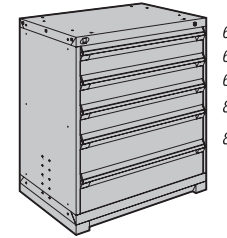

5 drawers
R5AEC-3805 36" x 18" x 40"
R5AEE-3805 36" x 24" x 40"

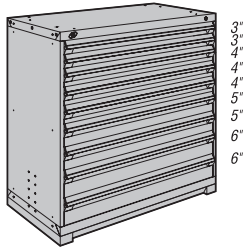

9 drawers
R5AHE-4405 48" x 24" x 46"
R5AHG-4405 48" x 27" x 46"

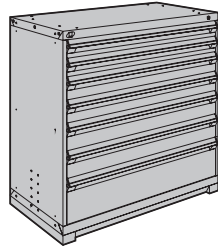

7 drawers
R5AHE-4407 48" x 24" x 46"
R5AHG-4407 48" x 27" x 46"

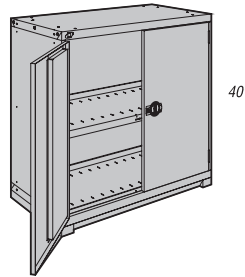

Double door / 1 adjustable shelf / 1 bottom shelf
R5AHE-4414 48" x 24" x 46"
R5AHG-4414 48" x 27" x 46"

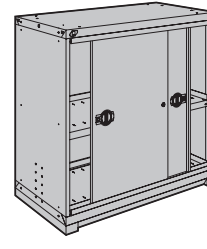

1 sliding door / 1 adjustable shelf / 1 bottom shelf
R5AHE-4416 48" x 24" x 46"
R5AHG-4416 48" x 27" x 46"

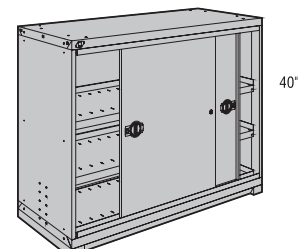

1 sliding door / 2 adjustable shelves / 1 bottom shelf
R5AKE-4406 60" x 24" x 46"
R5AKG-4406 60" x 27" x 46"

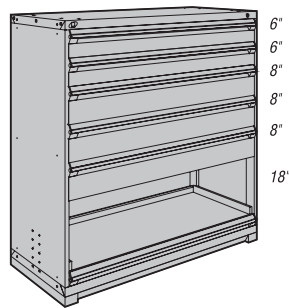

5 drawers / 1 roll-out shelf
R5AKE-5801 60" x 24" x 60"
R5AKG-5801 60" x 27" x 60"

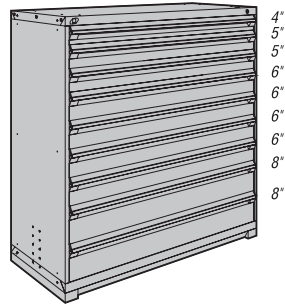

9 drawers
R5AKE-5803 60" x 24" x 60"
R5AKG-5803 60" x 27" x 60"

Shown here are several of the more popular heavy-duty modular cabinet models.

All proposals include a 2" front-access forklift base and a lock on the cabinet housing or on the door.

Drawer partitions are included in models.

Number of compartments (layout code)

Drawer dimensions	36" x 18"	36" x 24"	48" x 24"	48" x 27"	60" x 24"	60" x 27"
3" to 5"	24 (0518)	30 (0524)	40 (0732)	32 (0724)	70 (1356)	84 (1370)
6" to 8"	8 (0304)	12 (0308)	15 (0410)	15 (0410)	24 (0716)	21 (0614)
9" and higher	6 (0203)	9 (0206)	8 (0304)	8 (0304)	12 (0308)	12 (0308)

PARTS CASES - STEEL

Sliding drawer parts cabinets provide a convenient parts storage system with the flexibility of removable drawers, and a large assortment of drawer configurations. Drawers are housed in a 'sliding' drawer cabinet, and may be mounted on a raised base. Small (13 1/4" x 9 1/4" x 2") and large (18" x 12" x 3") drawers are available.



Model No: 4LR
Drawer Cabinet
(drawers sold separately).



Model No: DL24-C
Drawer.

SLIDING DRAWER CABINETS

These cabinets feature sliding drawer carriages that extend 100% of the drawers depth for easy access to parts. Cabinets are available for both the small and large drawer sizes. Drawers are sold separately.

Model No.	For Drawer:	Drawer Capacity	Wt. Lbs.
2LR	Large	2	20
4LR	Large	4	34
4SR	Small	4	22
6SR	Small	6	32

STEEL "SCOOP" DRAWERS

These fixed compartment drawers allow you to store and remove your small parts easily. Choose from between 8 and 32 compartment fixed drawers in either the small (13 1/4" x 9 1/4" x 2") or large (18" x 12" x 3") drawer size. Manufactured of prime cold rolled steel and finished in rust and acid resistant baked enamel, drawers have inserts of high impact plastic. These inserts have rounded scoops, making it easy to remove small parts. All models have covers designed to stay open for easy access, making it simple to read the cover labels. Durham Storage Drawers also have handles and a catch. See Chart below for Models.



CABINET BASES

Cabinet bases raise your cabinet/drawer combination 12" off of the floor or work bench for easier access to drawers. Models are available to adapt to both small and large drawer size cabinets.

Model No.	For Drawer:	Wt. Lbs.
BLR-S	Large	13
BSR-S	Small	12



ADJUSTABLE DRAWERS

Adjustable drawers provide the added flexibility of arranging your drawers according to your changing needs. Removable dividers can be "slotted" into place, or removed altogether.

Model No.	Drawer Size	Wt. Lbs.
ADL-C	Large	8
ADS-C	Small	4

Fixed drawer configurations (order by number of compartments)

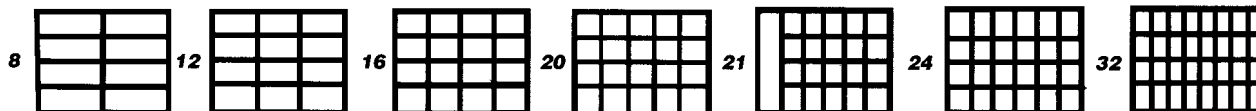

Number of Compartments	Large Drawers (18" x 12" x 3")		Small Drawers (13 1/4" x 9 1/4" x 2")	
	Model No.	Wt. Lbs.	Model No.	Wt. Lbs.
8	-	-	DS8-C	4
12	DL12-C	8	DS12-C	4
16	DL16-C	8	DS16-C	4
20	DL20-C	8	DS20-C	4
21	DL21-C	8	DS21-C	4
24	DL24-C	8	DS24-C	4
32	DL32-C	8	-	-

JUMBO DRAWER CABINETS



**OVER
3 feet high**

Practical, Efficient and Economical

The KLETON drawer cabinets combine all three characteristics to provide the best value available in an industrial grade parts storage system. Four different Jumbo-sized transparent plastic drawers allow you to store larger tools or materials close at hand. Drawers are housed in an all welded steel cabinet measuring over 3 feet high. Each drawer features an I.D. card with a clear plastic shield. Steel tabs prevent drawers from spilling their contents when pulled out. Cabinets are finished in grey enamel. Drawer dividers included.

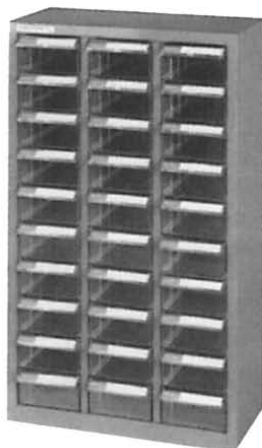
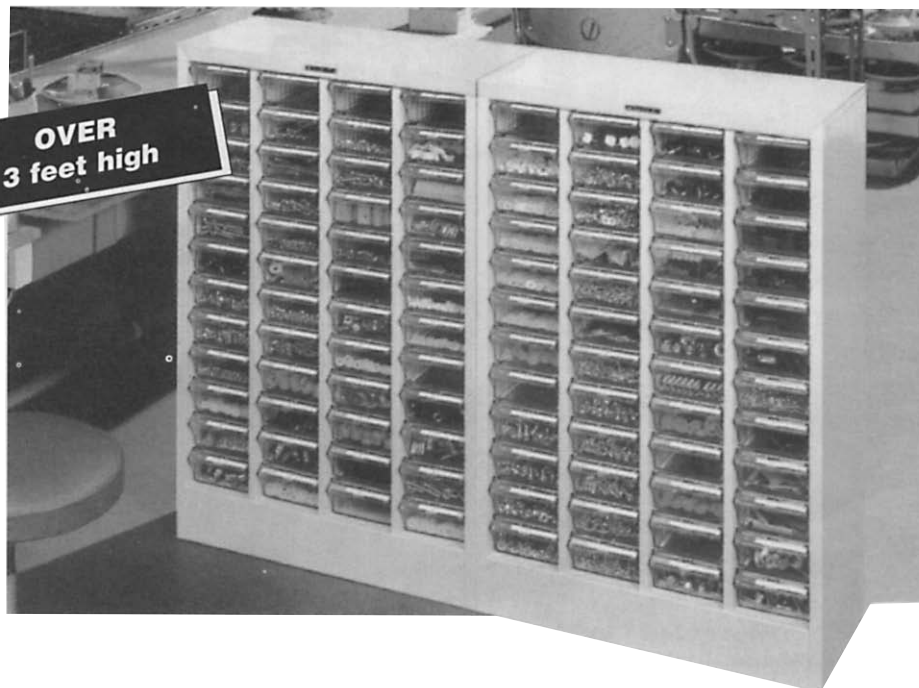

Model No. A6-330H

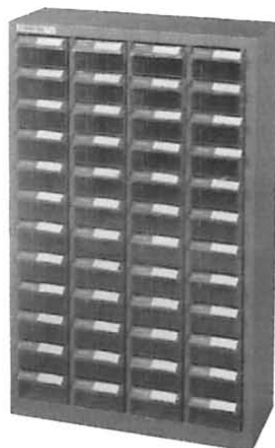

Model No. A7-448P

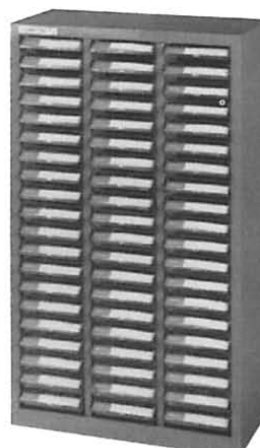

Model No. A6-360P

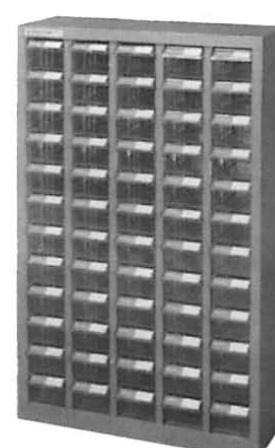

Model No. A8-560P

Model No.	No. of Drawers	Drawer Size						Cabinet Size				Wt. Lbs.
		D"	x	W"	x	H"	D"	x	W"	x	H"	
A6-330H	30	9.6	x	5.6	x	3.3	10.4	x	21.3	x	37	58
A7-448P	48	8.6	x	4.7	x	2.8	8.7	x	22.6	x	37	58
A6-360P	60	9.6	x	5.6	x	1.6	10.4	x	21.3	x	37	69
A8-560P	60	8.5	x	3.5	x	2.8	8.7	x	22.6	x	37	69

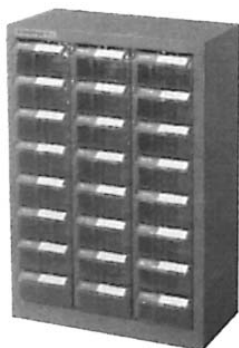

Model No. A7-324

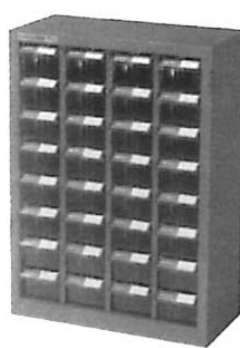

Model No. A8-432

WORKBENCH CABINETS

Ideal for storing parts etc ... right on your workbench, these two KLETON Jumbo drawer cabinets provide the high drawer load capacities of full sized Jumbo cabinets. Available with 24 drawers (8.6"D x 4.7"W x 2.8"H each) or with 32 drawers (7.1"D x 3.5"W x 2.8"H each). All-welded steel cabinets are finished in grey enamel. Drawer dividers included.

Model No.	No. of Drawers	Cabinet Size				Wt. lbs.	
		D"	x	W"	x		H"
A7-324	24	8.7	x	17.3	x	25.6	33.0
A8-432	32	8.5	x	18.0	x	25.6	33.2

PARTS CABINETS

'Carousel' Drawer Cabinets

Designed to utilize open and often unused areas such as corners, these rotary carousel units provide convenience for small parts storage. All-welded cabinets feature clear drawers, dividers, and I.D. labels. Blue enamel finish. Turntable model R-3 may be set up with up to 3 levels of 4 cabinets per level.

Model No.	Description	No. of Drawers	Cabinet Sizes			Wt. Lbs.
			W."	H."	D."	
2260	Drawer Cabinet	60	12	22	5 3/4	10.7
2248	Drawer Cabinet	48	12	22	5 3/4	10.7
2230	Drawer Cabinet	30	12	22	5 3/4	10.7
2216	Drawer Cabinet	16	12	22	5 3/4	10.3
R-3*	3 Tier Turntable Unit	-	18	3	18	40.0

*Note: Cabinets are ordered separately.



Model No. 2216
16 Drawer Cabinet



Model No. 2230
30 Drawer Cabinet

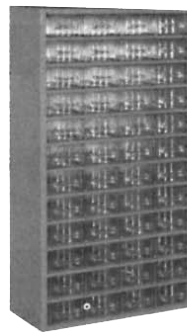

Model No. 2248
48 Drawer Cabinet

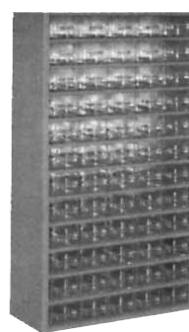

Model No. 2260
60 Drawer Cabinet

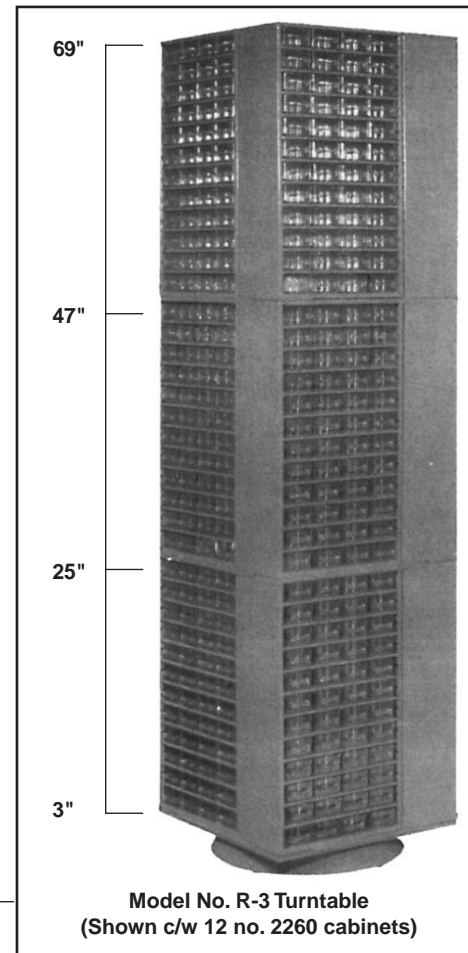

Portable Organizers

- Combination small and large parts storage
- Unique design keeps parts and equipment from migrating to other compartments when lids are shut
- Separate lid compartment holds small items
- The main compartment holds larger, bulky items
- Dividers included for both levels
- Molded-in 'feet' allow case to stand upright
- Organizers are blue with clear lids and black latches.
(Flat bottom organizer has orange latches)

Model No	Description	No. of Compartments	Size (L x W x H)
06115	Lid Storage Organizer	11 to 46	15" x 11 ⁵ / ₁₆ " x 3 ¹ / ₄ "
06118	Large Lid Storage Organizer	12 to 62	18 ¹ / ₄ " x 13 ³ / ₈ " x 3 ⁵ / ₈ "
06217	Flat Bottom Organizer	9 to 32	11 ¹⁵ / ₁₆ " x 15 x 3 ⁷ / ₈ "



HEAVY-DUTY DRAWER CABINETS

- Heavy-duty parts cabinets feature break resistant high impact clear plastic "scoop" drawers for easy removal of small parts, with two adjustable compartment dividers
- Drawers measure 2⁷/₈"W x 5¹/₂"D x 1⁷/₈"H each
- Welded steel cabinets are finished in blue baked enamel

Model No	No. of Drawers	Size (L x W x H)	Wt./lbs.
CA899	64	25 ¹ / ₂ " x 6 ¹ / ₂ " x 21 ³ / ₄ "	34
CA898	20	16 ¹ / ₂ " x 6 ¹ / ₂ " x 11 ¹ / ₄ "	12

MODULAR PARTS CABINETS

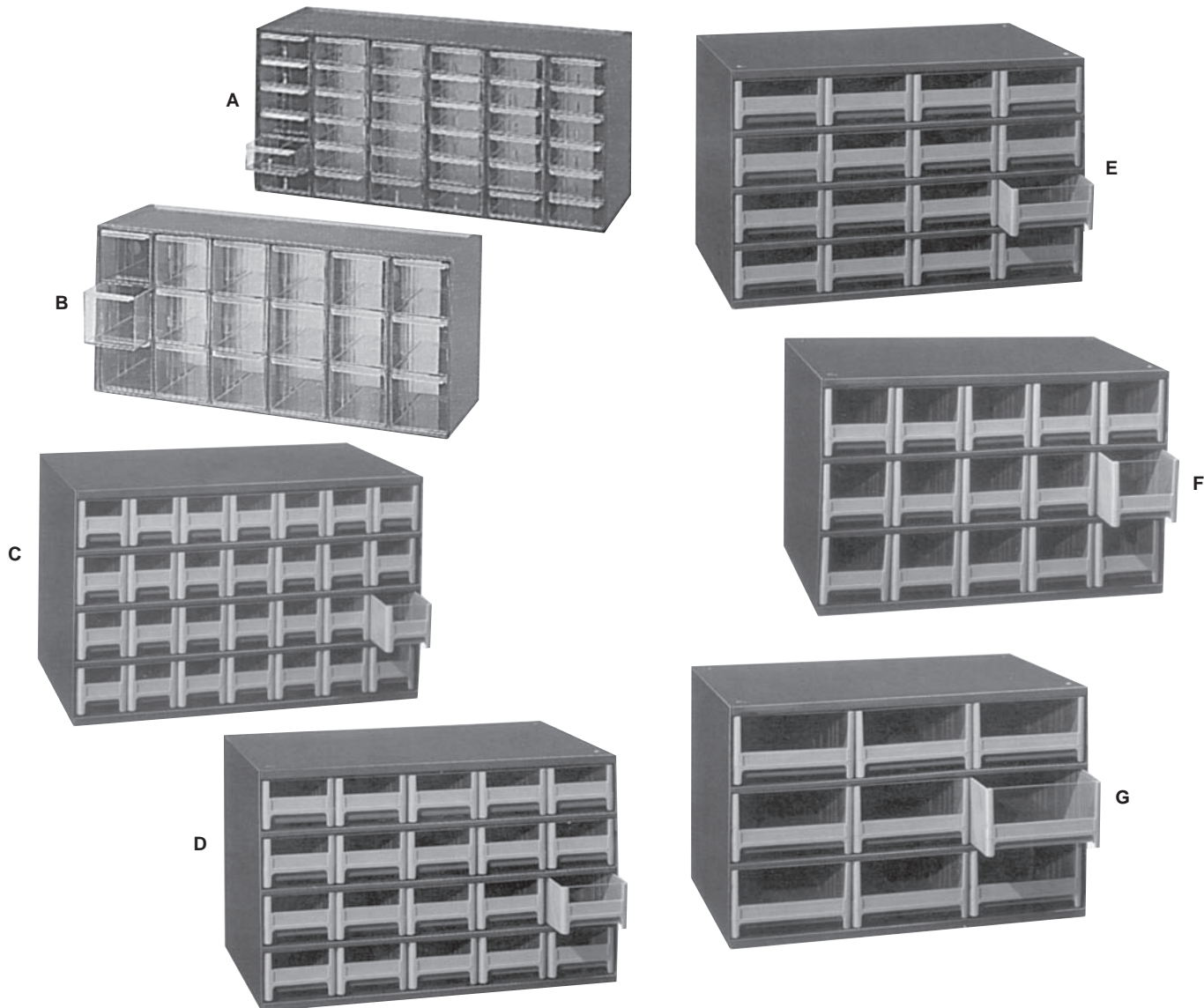

Modular Parts Cabinets

Organize and control small parts inventory. These cabinets save time and add efficiency to assembly lines, service centers, warehouses, and wherever small parts are used, stored or distributed. Opaque light grey, hi-impact polystyrene plastic drawers are virtually indestructible.

A transparent window on drawer front enables user to see inside, and a molded label holder on drawer pull provides instant identification. Economy models 17-136 and 17-018 feature all transparent styrene drawers. Drawers can be removed as needed but have a molded-in stop tab that prevents accidental spills.

Two removable dividers are furnished with each drawer. Cabinet frames are welded steel which is lightweight yet strong enough to stack on top of one another; mix or match units as needed, no assembly required. Built in nesting feet assure stability. Cabinets have chipproof baked enamel charcoal grey finish.

Figure	Model No.	No. of Drawers	Drawer Dimensions			Cabinet Dimensions			Weight lbs.
			W"	H"	D"	W"	H"	D"	
A	17-136*	36	2 ⁵ / ₈	1 ¹ / ₈	5 ³ / ₄	18	9 ¹ / ₂	6	12
B	17-018*	18	2 ⁵ / ₈	2 ¹ / ₂	5 ³ / ₄	18	9 ¹ / ₂	6	10
C	19-228	28	2 ³ / ₈	2 ¹ / ₄	11	17	11	11	24
D	19-320	20	3 ⁵ / ₁₆	2 ¹ / ₄	11	17	11	11	21
E	19-416	16	4 ³ / ₁₆	2 ¹ / ₄	11	17	11	11	20
F	19-715	15	3 ³ / ₈	3 ³ / ₁₆	11	17	11	11	20
G	19-909	9	5 ³ / ₁₆	3 ³ / ₁₆	11	17	11	11	18

*Comes with one divider per drawer

PLASTIC STORAGE UNITS

Storage-Go-Round Rotating storage system

- New improved steel rotating base.
- Store and organize up to 1/2 ton of parts, tools and products.
- Access to as many as 560 drawers in less than 1 square yard of floor space.
- Up to 20 modular cabinets may be used in any combination. Series 1900. 5 cabinets high on the turntable base.
- Assembled Storage-Go-Round is 31" wide x 60" high x 31" deep. Shipped unassembled.



Stock No	Description	Size (Inches)
98-325	Rotating base and stabilizer clips	31" x 31"
	Cabinets extra	

Mobile Modular Rack

- 500 pounds of small parts on wheels.
- Holds 12 or 16 multi-drawer cabinets. Series 1900. Use any combination of cabinets.
- Mounted on a 4 wheel rack.
- Assembled rack measures 36" long x 24" wide x 57" high.
- Provides access to as many as 336 drawers.
- Heavy-duty steel double-sided rack features reinforced braces.
- 4" rubber wheel casters.
- Locking wheel to prevent rolling when stopped.
- Cabinets mount to rack with 2 modular suspension straps.
- Straps fit into keyhole slots in cabinet frames.

Model No. 30-012C

12 Rail Rack, Cabinets extra

Model No. 30-016C

16 Rail Rack, Cabinets extra.

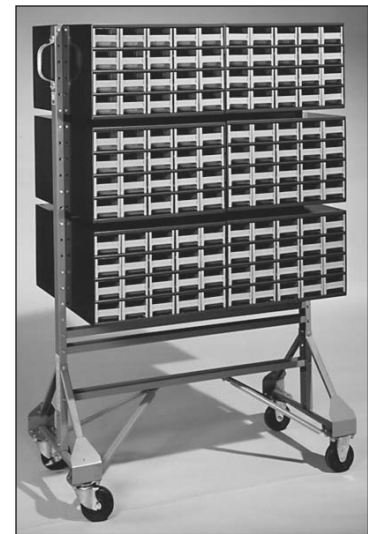

Model No. 30-12C

Roto-Shelf

Mobile storage rack for easy use

The Roto-Shelf mobile storage rack provides an easy way to move parts or tools anywhere in the shop, while taking up very little floor space. Four heavy-duty structural foam shelves rotate on a central metal shaft. Each shelf is divided into six sections. The distance between shelves is 7⁷/₈"

Model No. 02-420

19³/₄"W x 37¹/₂"L

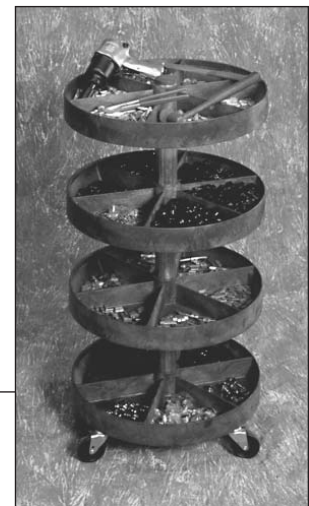

Plastic Storage Cabinets



10116



10126



10144



10164

16-Drawer Cabinet has 8 dividers.
All other cabinets have 8 small and 4 large dividers.

Features:

- Strong plastic cabinets organize and protect components
- Cabinets stack securely and are wall mountable
- A variety of drawer configurations provide versatile storage solutions
- Transparent dividable drawers offer easy content identification
- Finger-grip drawer pulls provide easy access



I.D. size: 4³/₈ W x 2 H x 5¹/₄ L



I.D. size: 2¹/₈ W x 1¹/₂ H x 5¹/₄ L

Storage Cabinets

Model No.	Description	Inches		
		L	W	H
10116	16-Drawer Cabinet	10 ⁹ / ₁₆	6 ³ / ₈	8 ¹ / ₂
10124	24-Drawer Cabinet	20	6 ³ / ₈	15 ¹³ / ₁₆
10126	26-Drawer Cabinet	20	6 ³ / ₈	10 ¹¹ / ₃₂
10144	44-Drawer Cabinet	20	6 ³ / ₈	15 ¹³ / ₁₆
10164	64-Drawer Cabinet	20	6 ³ / ₈	15 ¹³ / ₁₆

STEEL DRAWER CABINETS & TRUCKS

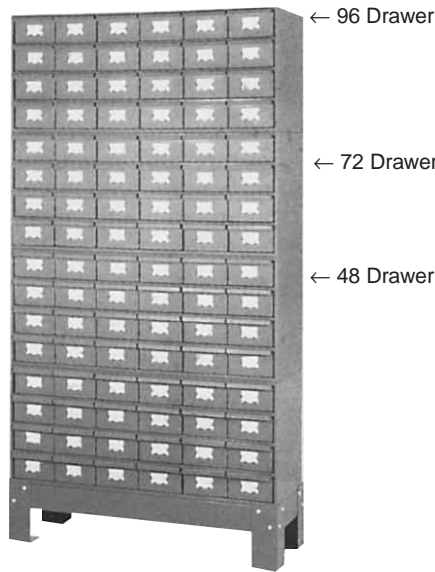

A. 48, 72 and 96 Drawer Cabinets
(Base included)

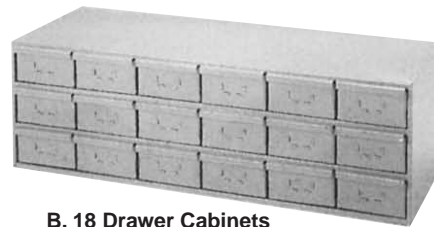

B. 18 Drawer Cabinets



D. 9 Drawer Cabinets

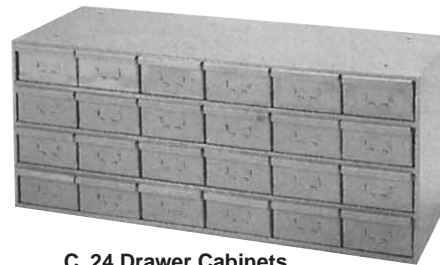

C. 24 Drawer Cabinets



E. 30 Drawer Cabinets

A - E. DURHAM INDUSTRIAL DRAWER CABINETS

Durham Industrial Drawer Cabinets provide a rugged modular storage system for small parts. Select from a range of drawer capacities from 9 drawers to 96 drawers per cabinet. Various drawer sizes are available including drawer heights of 2", 2 3/4" and 3 1/2", and drawer depths of 11 1/8" and 17". Each drawer includes 2 adjustable dividers, full width handles for easy opening and a card holder for content identification.

Drawer sides are slotted to hold dividers. Two dividers are provided with each drawer and a special snap-in feature keeps them in place, yet they are easy to remove. Each divider is embossed with a card holder. Colour: Grey.



Type	Model No.	No. of Drawers	Drawer Size				Cabinet Height"	Wt. Lbs.	
			W"	x	H"	x	D"		
A	48D	48	5 1/4	x	2 3/4	x	11 1/8	43	176
A	72D	72	5 1/4	x	2 3/4	x	11 1/8	54	238
A	96D	96	5 1/4	x	2 3/4	x	11 1/8	65	300
B	18D	18	5 1/4	x	2 3/4	x	11 1/8	10 7/8	50
B	18DR11	18	5 1/4	x	3 1/2	x	11 1/8	12 3/4	87
B	18DR17	18	5 1/4	x	3 1/2	x	17	12 3/4	75
C	24D	24	5 1/4	x	2 3/4	x	11 1/8	14 1/4	60
C	24DR17	24	5 1/4	x	3 1/2	x	17	16 7/8	96
D	9D	9	5 1/4	x	2 3/4	x	11 1/8	10 7/8	28
E	30DR11	30	5 1/4	x	3 1/2	x	11 1/8	21 1/8	87
E	30DR17	30	5 1/4	x	3 1/2	x	17	21 1/8	118
—	D2.75	Extra Divider for 2 3/4"H. Drawer							0.1
—	D3.50	Extra Divider for 3 1/2" H. Drawer							0.1

HEAVY-DUTY 2-SIDED MOBILE CART/WORK STATIONS

- Two rigid and two swivel casters with locking brakes
- Sturdy tubular handle allows ease of mobility
- Rubber tray mat provides safe, secure, non-skid work surface
- Finished in rust and acid resistant powder coated, grey baked enamel
- Heavy-duty casters, capacity of 1000 lbs.

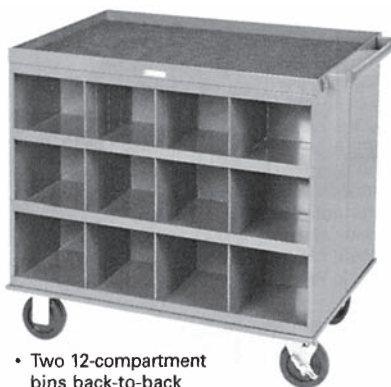

- Two 12-compartment bins back-to-back
- Overall dimensions: 24" W x 34" D x 32" H
- Ship weight is: 139 lbs.

Model No. CD330

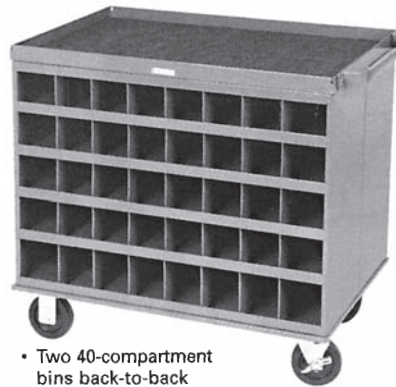

- Two 40-compartment bins back-to-back
- Overall dimensions: 24" W x 34" D x 32" H
- Ship weight: 159 lbs.

Model No. CD349

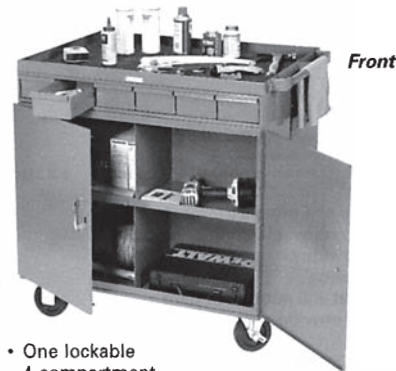

- One lockable 4-compartment storage cabinet
- One storage bin with 12 compartments
- 12 easily dividable pull out storage drawers, six on each side
- Overall dimensions: 24" W x 34" D x 36" H
- Ship weight: 180 lbs.

Model No. CD348