

LIFTING EQUIPMENT

PORTABLE SHOP CRANE

This versatile crane provides lifting power to any job site. Fast and easy assembly/disassembly. Disassembled unit fits easily into the trunk of a car. Heaviest piece weighs 40 lbs. This crane is equipped with heavy duty cast iron wheels, manual pump, safety hook and push handle. Shipped knocked down.

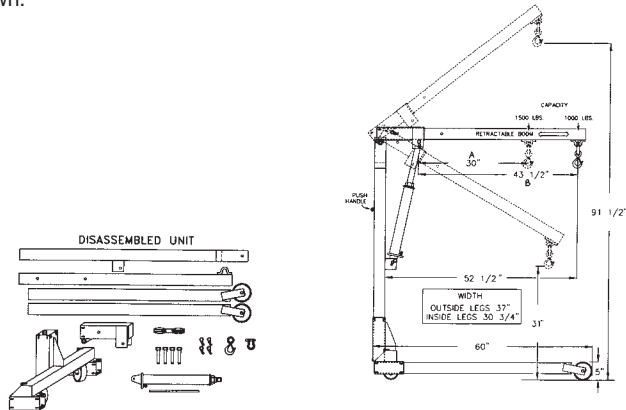

Model No.	Boom Reach"/ Capacity lbs.		Lift Clearance		Width Inside Legs"	Wt. lbs.
	A	B	Min"	Max"		
LA791	30/1500	43 1/2/1000	31	91 1/2	30 3/4	230
Replacement Pump & Repair Kit						
LA838	Replacement hydraulic pump					
LA839	Pump (seals) repair kit					

DURABILT SERIES FROM NORTH

FEATURES:

- Priced right to satisfy your needs
- User friendly
- Polyester webbing for greater resistance to chemicals
- Large Back D-ring
- Universal style with our one size fits most

SAFETY & QUALITY

- Meets or exceeds all standards CSA, ANSI and OHSA
- *North* doesn't just make it, they make sure it works: *North* tests all products to all applicable standards to ensure your safety
- ISO 9001 manufacturing facility

COST EFFECTIVENESS

- Basic universal harness for everyday use
- Requires less sizes to carry
- No bells and whistles
- Lightweight
- Everything you will need in one kit (bag included)
- No sacrificing of quality for a better price

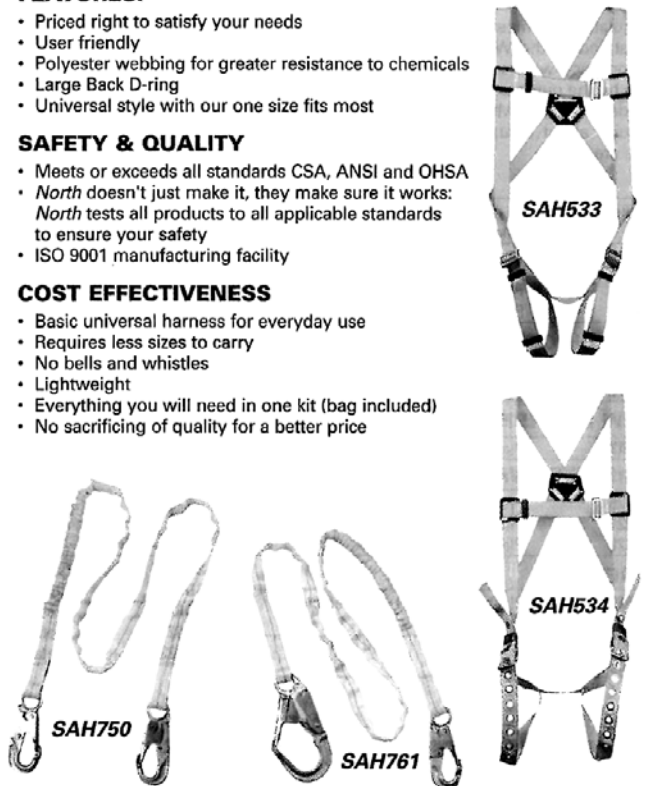

CHECKERBOOM FORKLIFT HOOK ATTACHMENT



- Maximum lifting capacity: 4000 lb, 10,000 lb or 15,000 lb
- 25" overall width
- 24" fork spread
- Converts your forklift truck to a mobile crane
- Heavy steel frame with swivel hook
- Rapidly attaches to forks by tightening two wing nuts
- Load can be supported at any position along the forks
- Other capacities available upon request

Model No Forklift Capacity (lbs)

F45-2	4,000
F45-1	10,000
F45-7	15,000

RETRACTABLE WEB LANYARDS

- 8' (2.4 m) long w/locking swivel snap hook
- Retractable web lanyards are the lightest SRL's available
- Engineered to provide maximum protection in places where lanyards might get in the way
- Equipped with 2" (50 mm) webbing, a tough vinyl cover and mounting karabiner
- CSA type: Fall Arrest type 1



APPLICATIONS:

- General fall protection
- Stock pickers in warehouses
- Aerial lift applications (i.e. scissor-lifts)
- Also available in other configurations to suit a variety of applications upon request

Model No. **SN122**
Mfg. No. FP0304

HARNESSES

Model No.	Mfg. No.	Description
SAH533	FPD698/1DP	Full body harness
SAH534	FPD698/1DGP	Full body harness w/grommetted legs

LANYARDS

Polyester decelerator energy absorbing lanyard with double locking snap hook harness connectors.

Model No.	Mfg. No.	Anchors Connectors	Length'
SAH537	FPD29811/4	Double locking snap hook	4
SAH750	FPD29811/6	Double locking snap hook	6
SAH538	FPD29819/4	Double locking rebar hook	4
SAH761	FPD29819/6	Double locking rebar hook	6