

FEATHERLITE ALUMINUM LADDERS

Series 3400 Heavy Duty Aluminum Steps

CSA approved Grade 1 - 250lb load rating.
Meets or exceeds ANSI Type 1 - 250 lb load rating.
High strength to weight ratio provides an economical alternative for general contractor work.

Part No.	Size	Open Height	Highest Safe Standing Ht.	Base Width	Base Depth	App. Wt.
3404	4'	46"	24"	19"	30"	12 lbs
3405	5'	57"	34"	20"	35"	14 lbs
3406	6'	68"	46"	21"	41"	17 lbs
3408	8'	91"	68"	24"	54"	22 lbs
3410	10'	114"	91"	26"	67"	28 lbs

Series 4400 Extra Heavy Duty Aluminum Step

CSA approved, Grade 1- 250lb load rating. Meets or exceeds ANSI Type 1A - 300lb load rating. Built to last in any industrial application.

Part No.	Size	Open Height	Highest Safe Standing Ht.	Base Width	Base Depth	App. Wt.
4404	4'	46"	24"	20"	29"	14 lbs
4406	6'	68"	46"	23"	41"	20 lbs
4408	8'	90"	68"	26"	54"	26 lbs
4410	10'	113"	91"	29"	66"	33 lbs
4412	12'	135"	114"	32"	78"	41 lbs
4414	14'	158"	134"	35"	88"	51 lbs
4416	16'	181"	160"	38"	102"	59 lbs

Series 3500 Heavy Duty Aluminum Platform Steps

CSA approved Grade 1 - 250lb load rating.
Meets or exceeds ANSI Type 1 - 250 lb load rating.
Ideal for general fixed height work.

Part No.	Size	Open Height	Vertical Ht. to Platform	Base Width	Base Depth	App. Wt.
3504	4'	46"	23"	21"	28"	13 lbs
3506	6'	68"	46"	24"	42"	19 lbs
3508	8'	90"	68"	26"	54"	24 lbs
3510	10'	114"	92"	29"	66"	30 lbs

Series 4500

Extra Heavy Duty Aluminum Platform Step

CSA approved Grade 1 - 250lb load rating.
Meets or exceeds ANSI Type 1A - 300 lb load rating.
Ideal for industrial fixed height work

Part No.	Size	Open Height	Vertical Ht. to Platform	Base Width	Base Depth	App. Wt.
4506	6'	68"	46"	24"	42"	22 lbs
4508	8'	93"	69"	27"	54"	28 lbs
4510	10'	113"	92"	31"	65"	35 lbs
4512	12'	135"	115"	34"	78"	43 lbs
4514	14'	157"	136"	36"	87"	52 lbs
4516	16'	180"	158"	39"	102"	60 lbs

Series 3600 Heavy Duty Aluminum Two-Way Step

CSA approved Grade 1 - 250lb load rating.
Meets or exceeds ANSI Type 1 - 250 lb load rating.
Double front construction allows access from either side.

Part No.	Size	Open Height	Safe Standing Ht.	Base Width	Base Depth	App. Wt.
3604	4'	44"	23"	19"	39"	14 lbs
3606	6'	68"	45"	21"	57"	21 lbs
3608	8'	90"	67"	24"	72"	29 lbs
3610	10'	112"	89"	26"	89"	36 lbs

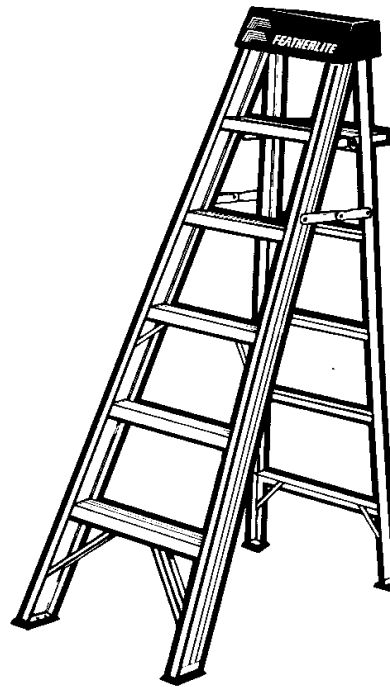

Series 3400 & 4400



Series 3500 & 4500

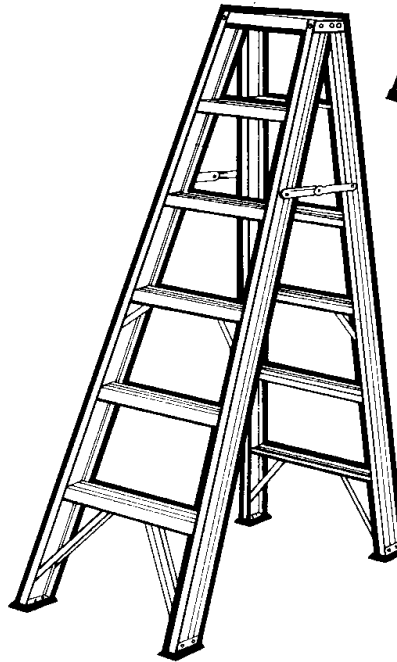

Series 3600 & 4600

Series 4600

Extra Heavy Duty Aluminum Two-Way Step

CSA approved Grade 1 - 250lb load rating.
Meets or exceeds ANSI Type 1A - 300 lb load rating.
Double front construction allows access from either side.

Part No.	Size	Open Height	Highest Safe Standing Ht.	Base Width	Base Depth	App. Wt.
4606	6'	67"	46"	23"	56"	25 lbs
4608	8'	90"	68"	26"	73"	32 lbs
4610	10'	112"	90"	29"	89"	41 lbs

FEATHERLITE ALUMINUM LADDERS

Series 3200 Heavy Duty Aluminum Extension

CSA approved Grade 1 - 250lb load rating.
Meets or exceeds ANSI Type 1 - 250 lb load rating.
Heavy duty "I" Beam construction, 3¹/₁₆" x 1¹/₄" rails provide stability, torque resistance and high strength to weight ratio. Round Rung. For D Rung, add D to part number.

Two Section Extension

Part No.	Size	Max Ext. Length	Base Section		Fly Section		Approx. Wt.
			O/S Width	I/S Width	O/S Width	I/S Width	
3216	16'	13'	17 ⁵ / ₈ "	15 ¹ / ₈ "	16 ³ / ₈ "	13 ³ / ₄ "	29 lbs
3220	20'	17'	17 ⁵ / ₈ "	15 ¹ / ₈ "	16 ³ / ₈ "	13 ³ / ₄ "	34 lbs
3224	24'	21'	17 ⁵ / ₈ "	15 ¹ / ₈ "	16 ³ / ₈ "	13 ³ / ₄ "	41 lbs
3228	28'	25'	17 ⁵ / ₈ "	15 ¹ / ₈ "	16 ³ / ₈ "	13 ³ / ₄ "	50 lbs
3232	32'	29'	17 ³ / ₄ "	15 ¹ / ₄ "	16 ¹ / ₄ "	13 ³ / ₄ "	57 lbs
3236	36'	32'	17 ³ / ₄ "	15 ¹ / ₄ "	16 ¹ / ₄ "	13 ³ / ₄ "	66 lbs
3240	40'	35'	17 ³ / ₄ "	15 ¹ / ₄ "	16 ¹ / ₄ "	13 ³ / ₄ "	73 lbs

Series 4100 & 4200

Extra Heavy Duty Aluminum Extension & Straight

CSA approved Grade 1 - 250lb load rating. D Rung except 4360.
Meets or exceeds ANSI Type 1A -300 lb load rating.
Our signature product. Possibly the best designed and manufactured ladder in the world. Rigid "Box-Section" side rails. Unequaled for strength and durability.

Two Section Extension

Part No.	Size	Max Ext. Length	Base Section		Fly Section		Approx. Wt.
			O/S Width	I/S Width	O/S Width	I/S Width	
4216	16'	13'	17 ¹ / ₁₆ "	15 ¹ / ₄ "	14 ⁵ / ₈ "	12 ⁷ / ₈ "	28 lbs
4220	20'	17'	17 ¹ / ₁₆ "	15 ¹ / ₄ "	14 ⁵ / ₈ "	12 ⁷ / ₈ "	35 lbs
4224	24'	21'	17 ¹ / ₁₆ "	15 ¹ / ₄ "	14 ⁵ / ₈ "	12 ⁷ / ₈ "	42 lbs
4228	28'	25'	17 ¹ / ₁₆ "	15 ¹ / ₄ "	14 ⁵ / ₈ "	12 ⁷ / ₈ "	47 lbs
4232	32'	29'	17 ¹ / ₁₆ "	15 ¹ / ₄ "	14 ⁵ / ₈ "	12 ⁷ / ₈ "	53 lbs
4236	36'	32'	18 ³ / ₈ "	16 ¹ / ₄ "	15 ⁷ / ₈ "	14"	68 lbs
4240	40'	35'	18 ³ / ₈ "	16 ¹ / ₄ "	15 ⁷ / ₈ "	14"	77 lbs
4244	44'	39'	18 ³ / ₈ "	16 ¹ / ₄ "	15 ⁷ / ₈ "	14"	91 lbs
4360	60'	50'	21 ³ / ₄ "	19"	16"	14 ¹ / ₈ "	128 lbs

Single Section Straight - Round Rung

Part No.	Size	O/S Width	I/S Width	Weight
4108	8'	14 ⁵ / ₈ "	12 ⁷ / ₈ "	13 lbs
4110	10'	14 ⁵ / ₈ "	12 ⁷ / ₈ "	16 lbs
4112	12'	14 ⁵ / ₈ "	12 ⁷ / ₈ "	19 lbs
4114	14'	14 ⁵ / ₈ "	12 ⁷ / ₈ "	22 lbs
4116	16'	14 ⁵ / ₈ "	12 ⁷ / ₈ "	25 lbs
4118	18'	14 ⁵ / ₈ "	12 ⁷ / ₈ "	28 lbs
4120	20'	14 ⁵ / ₈ "	12 ⁷ / ₈ "	31 lbs
4122	22'	16"	14"	41 lbs
4124	24'	16"	14"	44 lbs

Series 3700

Heavy Duty Aluminum Sawhorse Steps

The ideal drywall and general contractor's access tool.

Part No.	Size	Open Height	Base Width	Base Depth	App. Wt.
3702	2'	23"	32"	24 ¹ / ₂ "	10 lbs
3703	3'	35"	34 ¹ / ₂ "	32"	14 lbs
3704	4'	47 ¹ / ₂ "	34 ¹ / ₂ "	32"	19 lbs

Series 2700

Medium Duty Aluminum Multi-Way

CSA Approved Grade 2 - 225 lb load rating.
Meets or exceeds ANSI Type 2 - 225 lb load rating.
A tough, versatile ladder for the tradesman or do-it-yourselfer

Part No.	Step Ladder Size	Extension Ladder Size	Max. Ext. Open Length	Approx. Wt.
2706	6'	12'	9'	22 lbs
2707	7'	14'	11'	25 lbs
2708	8'	16'	13'	28 lbs

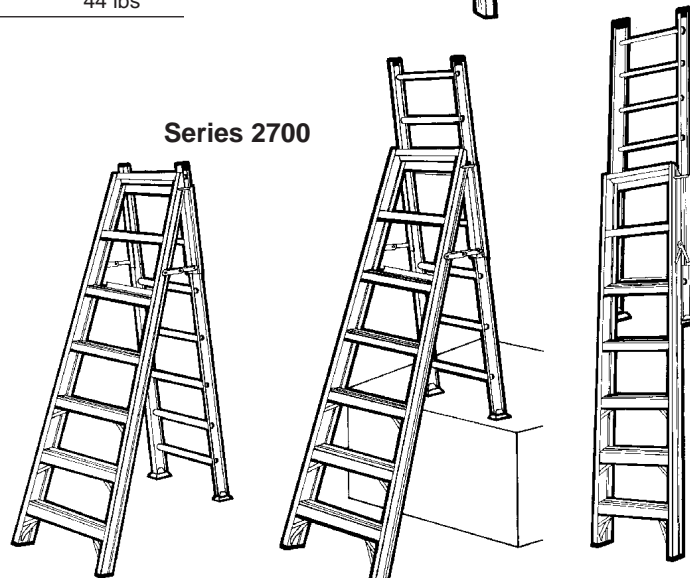
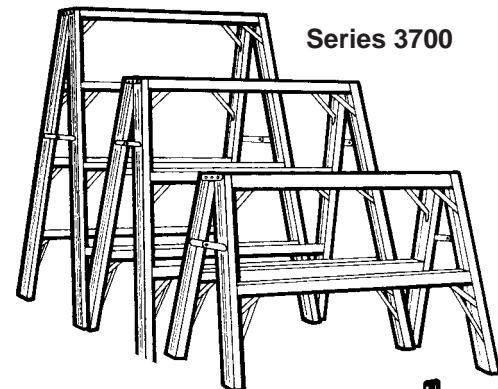
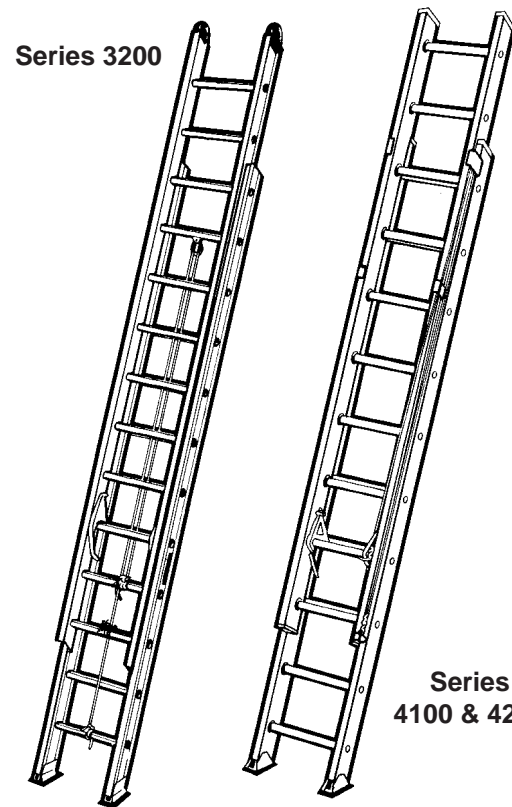

FEATHERLITE FIBREGLASS LADDERS

Series 6300 Heavy Duty Fibreglass Step

CSA approved, Grade 1 - 250lb load rating. Meets or exceeds ANSI Type 1 - 250lb load rating. High strength to weight ratio provides an economical alternative for general contractor work.

Part No.	Size	Open Height	Highest Safe Standing Ht.	Base Width	Base Depth	App. Wt.
6304	4'	46"	23"	19"	29"	11 lbs
6306	6'	68"	45"	21"	44"	17 lbs
6308	8'	90"	67"	23"	56"	21 lbs

Series 6400 Extra Heavy Duty Fibreglass Step

CSA approved Grade 1 - 250lb load rating. Meets or exceeds ANSI Type 1A - 300 lb load rating. Canada's #1 fibreglass step for all applications.

Part No.	Size	Open Height	Highest Safe Standing Ht.	Base Width	Base Depth	App. Wt.
6403	3'	34"	11"	17"	23"	12 lbs
6404	4'	46"	23"	18"	28"	16 lbs
6405	5'	57"	34"	20"	34"	19 lbs
6406	6'	68"	45"	21"	43"	22 lbs
6408	8'	90"	67"	23"	55"	30 lbs
6410	10'	113"	90"	26"	68"	36 lbs
6412	12'	137"	114"	28"	79"	45 lbs

Series 6500

Extra Heavy Duty Fibreglass Platform Step

CSA approved Grade 1 - 250lb load rating. Meets or exceeds ANSI Type 1A - 300 lb load rating. Ideal for all types of fixed height work

Part No.	Size	Open Height	Platform Height	Base Width	Base Depth	App. Wt.
6506	6'	68"	46"	24"	42"	25 lbs
6508	8'	90"	68"	28"	54"	33 lbs
6510	10'	113"	92"	31"	67"	41 lbs

Series 6600

Extra Heavy Duty Fibreglass Two-way Step

CSA approved Grade 1 - 250lb load rating. Meets or exceeds ANSI Type 1A - 300 lb load rating. Double-front construction allows access from either side.

Part No.	Size	Open Height	Highest Safe Standing Ht.	Base Width	Base Depth	App. Wt.
6606	6'	67"	45"	21"	60"	26 lbs
6608	8'	90"	67"	23"	75"	36 lbs
6610	10'	112"	89"	29"	92"	46 lbs

Series 6200 Extra Heavy Fibreglass Extension

CSA approved Grade 1 - 250lb load rating. Round Rung. For D Rung, add D to part number. Meets or exceeds ANSI Type 1A - 300 lb load rating.

Two Section Extension

Part No.	Size	Max Open Length	Base Section		Fly Section		Approx. Wt.
			O/S Width	I/S Width	O/S Width	I/S Width	
6216	16'	13'	17 ³ / ₈ "	15"	16 ⁵ / ₈ "	14 ¹ / ₄ "	38 lbs
6220	20'	17'	17 ³ / ₈ "	15"	16 ⁵ / ₈ "	14 ¹ / ₄ "	44 lbs
6222	22'	19'	17 ³ / ₈ "	15"	16 ⁵ / ₈ "	14 ¹ / ₄ "	48 lbs
6224	24'	21'	17 ³ / ₈ "	15"	16 ⁵ / ₈ "	14 ¹ / ₄ "	52 lbs
6228	28'	25'	17 ³ / ₈ "	15"	16 ⁵ / ₈ "	14 ¹ / ₄ "	59 lbs
6232	32'	28'	17 ³ / ₈ "	15"	16 ⁵ / ₈ "	14 ¹ / ₄ "	66 lbs
6236D	36'	32'	19"	15 ¹ / ₂ "	17 ³ / ₄ "	14 ¹ / ₄ "	96 lbs
6240D	40'	35'	19"	15 ¹ / ₂ "	17 ³ / ₄ "	14 ¹ / ₄ "	106 lbs

Single Section Straight - Round Rung

Part No.	Size	O/S Width	I/S Width	Weight
6108	8'	17 ³ / ₈ "	15"	18 lbs
6110	10'	17 ³ / ₈ "	15"	21 lbs
6112	12'	17 ³ / ₈ "	15"	24 lbs
6114	14'	17 ³ / ₈ "	15"	28 lbs
6116	16'	17 ³ / ₈ "	15"	32 lbs

Series 6900 Extra Heavy Duty Fibreglass Step

CSA approved Grade 1 - 300lb load rating. Meets or exceeds ANSI Type 1A - 300 lb load rating. Canada's #1 fibreglass step for all applications.

Part No.	Size	Open Height	Highest Standing Ht.	Base Width	Base Depth	Approx. Wt. Lbs.
6903	3'	34"	11"	19"	23"	12 lbs
6904	4'	46"	23"	20"	28"	15 lbs
6905	5'	57"	34"	21"	34"	18 lbs
6906	6'	68"	45"	23"	39"	21 lbs
6907	7'	79"	56"	24"	44"	25 lbs
6908	8'	90"	67"	25"	50"	28 lbs
6910	10'	113"	90"	28"	61"	36 lbs
6912	12'	137"	114"	31"	74"	48 lbs

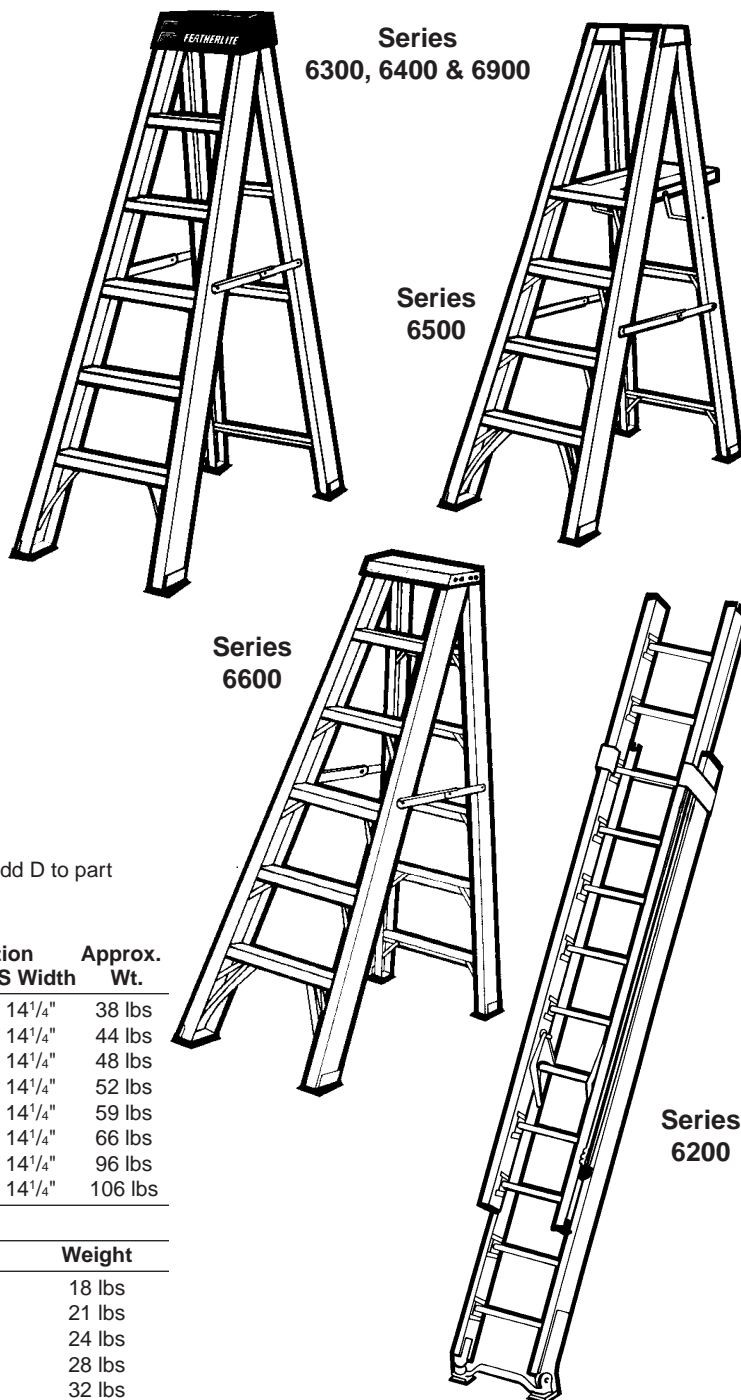

LADDERS & STEP STOOLS

Jaws telescopic climbing system.
Seven ladders in one. 5 sizes available to choose from.

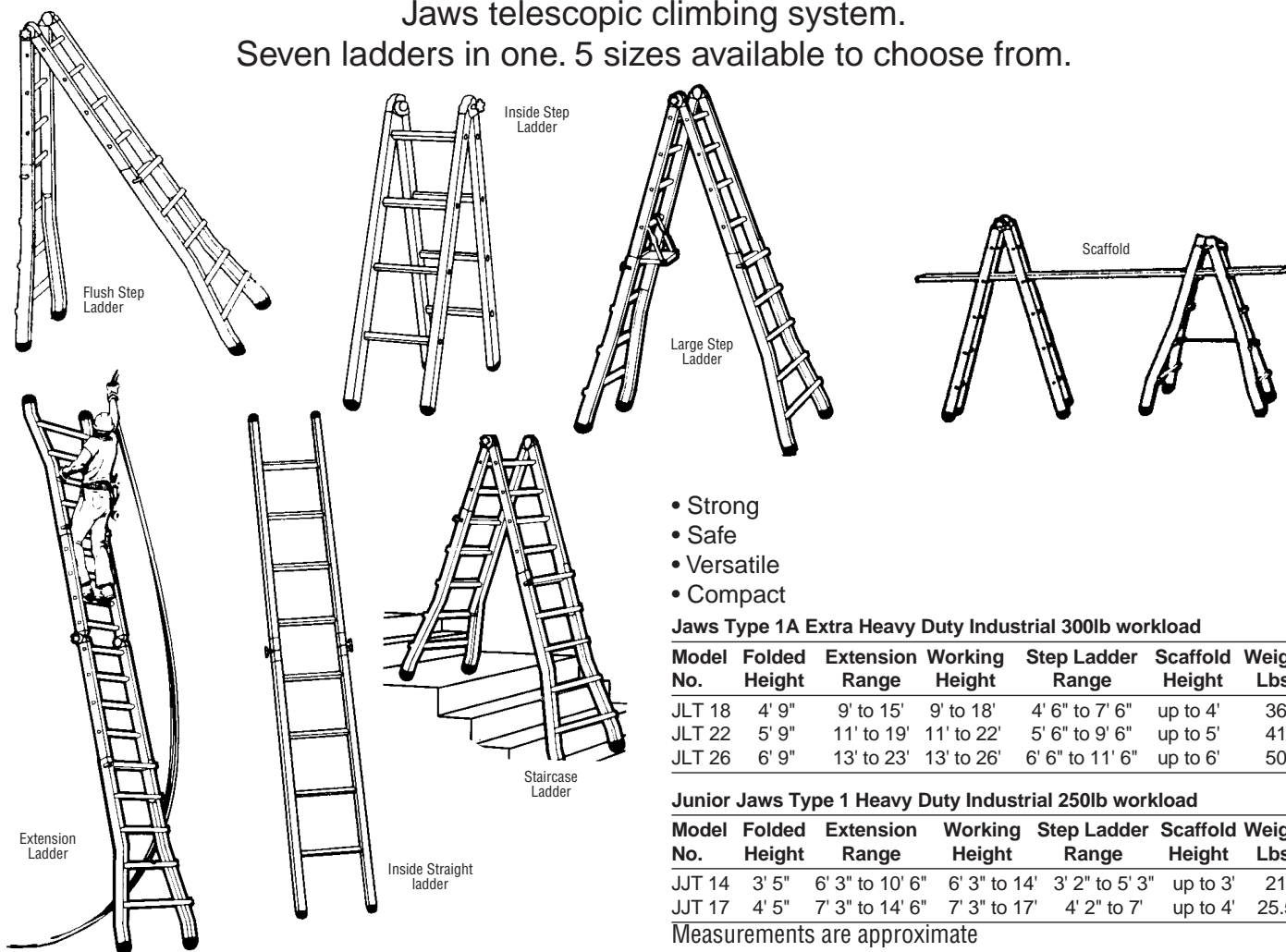

- Strong
- Safe
- Versatile
- Compact

Jaws Type 1A Extra Heavy Duty Industrial 300lb workload

Model No.	Folded Height	Extension Range	Working Height	Step Ladder Range	Scaffold Height	Weight Lbs.
JLT 18	4' 9"	9' to 15'	9' to 18'	4' 6" to 7' 6"	up to 4'	36
JLT 22	5' 9"	11' to 19'	11' to 22'	5' 6" to 9' 6"	up to 5'	41
JLT 26	6' 9"	13' to 23'	13' to 26'	6' 6" to 11' 6"	up to 6'	50

Junior Jaws Type 1 Heavy Duty Industrial 250lb workload

Model No.	Folded Height	Extension Range	Working Height	Step Ladder Range	Scaffold Height	Weight Lbs.
JJT 14	3' 5"	6' 3" to 10' 6"	6' 3" to 14'	3' 2" to 5' 3"	up to 3'	21
JJT 17	4' 5"	7' 3" to 14' 6"	7' 3" to 17'	4' 2" to 7'	up to 4'	25.5

Measurements are approximate

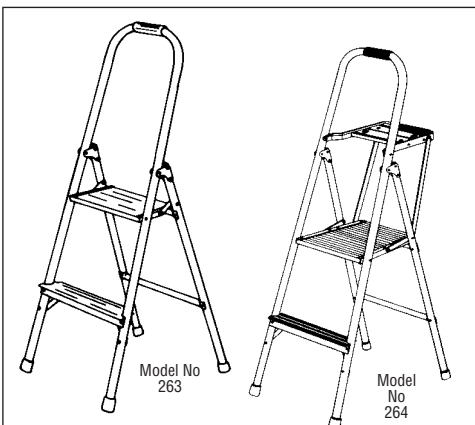

Light Duty Platform Ladders

CSA certified Grade 3. Tubular aluminum framing, handrail for climbing. Ideal for 8 ft ceilings. Model 264 comes with pail/rag holder and tool holder. Folds to 3 1/2". Non-marring vinyl tipped feet.

Model No.	Overall Ht."	Platform Ht."	Wt/Lbs
263	46	22	6
264	54	22	8



Steel Kik-Step

Model No. KS-2

Extra heavy duty steel kick step. The double platform has a non-slip rubber tread. Non-marring retractable casters. The base firmly "grabs" the floor as you climb. All-around bumper protects walls and furniture. Platform height: 14". Weight: 10 lbs.



Stepstool

Model No. 2523

Big 16" diameter base for added stability with treaded top and expanded step. Tough one-piece construction and anti-skid bottom with retractable casters. Available in two colours. Add suffix: **BL** for Black or **BE** for Beige. Weight: 7 lbs.